

TOOLS FOR LARGE FORMAT TILES



CUTTING SYSTEM

RAIZOR: CUTTING GUIDES	S2
ACCESSORIES AND SPARE PARTS FOR RAIZOR.....	S3
POWER RAIZOR: MULTI-ANGLE CUTTING UNIT	S4
BC45: DEVICE TO PERFORM 45° MITER CUT ("JOLLY")	S5
ACCESSORIES FOR POWER RAIZOR AND BC45.....	S6
T-CUT: DEVICE FOR SCORING AND CUTTING LARGE FORMAT TILES... S7	

MODULAR WORKING BENCHES

BM180 ^{PLUS} : ADJUSTABLE WIDTH MODULAR BENCH	S8
BM180 ^{MkII} : MODULAR WORKING BENCH.....	S9
EXTENSION FOR WORKING BENCHES.....	S10
TSE180: TILTING EXTENSION FOR BM180 ^{MkII} and BM 180 ^{PLUS} S11	
TILE-SUPPORT CYLINDERS & SIDE PROFILES FOR SCORING	S12
OTHER ACCESSORIES FOR WORKING BENCHES	S13

HANDLING SYSTEMS

EASY-MOVE ^{MkIV} WITH DOUBLE SUCTION ^{PLUS}	S14
EASY-MOVE ^{MkIV} WITH RV175 SUCTION CUPS (VACUUM).....	S15
EASY-MOVE 150 WITH RV175 SUCTION CUPS (VACUUM)	S16
POWER-VACUUM KIT	S17
ACCESSORIES AND SPARE PARTS FOR EASY-MOVE ^{MkIV}	S18
RV175 - VACUUM (PUMP) SUCTION CUP WITH GAUGE	S19
SINGLE, DOUBLE AND TRIPLE SUCTION CUPS	S20
ONLY-ONE: DEVIDE TO ASSIST INSTALLATION	S21

TROLLEY

CAM ^{MkIII} - MODULAR TROLLEY FOR TRANSPORT	S22
TYRREL (TRANSPORT CART) AND CORNER PROTECTORS.....	S23

TILES BEATING AND AIR EXPULSION

E-FOX (TILE-VIBRATOR) AND TILE BEATER	S24
---	-----

OTHER ACCESSORIES

CLOSER ^{PLUS} (TO ALIGN TILES) & LEVTOP (FOR TOP INSTALLATION) ..	S25
OTHER ACCESSORIES FOR LARGE FORMAT TILES.....	S26

DEVICE TO PERFORM CIRCULAR CUTS

MOTOKOMPASS: DEVICE TO PERFORM CIRCULAR CUTS	S27
KOMPASS: DEVICE TO PERFORM CIRCULAR CUTS.....	S28

DEVICE FOR CREATING STEPS AND COUNTERTOPS

TIP TOP: FACE-UP MITER-CLAMPING-DEVICE	S29
90° GLUING KIT	S30

The widest and most innovative range of equipment ideal for ceramic tiles slabs. Thanks to cutting rail RAIZOR and T-CUT device it is possible to perform perfect cuts with scoring method. POWER RAIZOR and BC45 cutting units allow to perform 45° cuts (Jolly), 90° cuts and with variable angles (also 180°).

The EASY-MOVE^{MkIV} frame and the wide range of suction cups are the ideal handling solution from glossy to heavy textured tiles/slabs. Furthermore, thanks to power-vacuum kit it is possible to create and keep the vacuum level on all vacuum suction cups. With ONLY-ONE and EASY-MOVE 150, 150x150 cm (4.9'x4.9') tiles can be handled and fixed by just a single operator.

The modular cart CAM^{MkIII} and trolley Tyrrel are the perfect solution to transport any tile/slab, also in narrow spaces. The BM180 benches supply a comfortable worktop for slabs of any size and, at the same time, are easily transportable. The PLUS version

can be widened from 100 to 150 cm (from 3.2' to 4.9') without any additional extensions. Now available a tilting workbench extension for BM180 designed to support tiles during the split phase after scoring.

To get our range even wider, E-FOX cordless vibrator and our manual rubber tile beater are extremely useful to embed slabs into bed of adhesive and eliminate any air pocket, left underneath the slab, to prevent potential cracks.

LEVTOP^{PLUS} and LEVTOP^{PLAT} are designed to install countertops and other furnishing elements, both at 90° and/or with other angles. Part of the range, also two gluing kit to make countertops and stair steps of any length, as well as KOMPASS and MOTOKOMPASS to perform score cutting and round shapes.

Last but not least, a wide range of diamond pads to finish edges after cutting.



RAIZOR – CUTTING SYSTEM FOR LARGE FORMAT TILES



433CRR



169TB RAI

PACKAGE



- Cutting system for large format tiles up to 332 cm - 10.9 ft. (447 cm - 14.7 ft. with optional extension), lightweight (9 Kg - 19.8 lbs) and easy to transport.
- RAIZOR is composed by:
 - two connectable guides with cutting length of 160 cm (5.2 ft.) each (332 cm - 10.9 ft. when combined);
 - die-cast cutting unit provided with wolfram carbide wheel Ø 16 mm (5/8") and pin (pin rotates on bearings);
 - cutting-off pliers for tiles/slabs with thickness from 3 to 12 mm (1/8" - 1/2");
 - everything packed in a padded bag with shoulder-straps and provided with inside modular compartments and pocket.
- The resistant padded bag protects the product and allow to carry it easily. It has adjustable compartments and inside pocket for placing personal belongings or work tools.
- Guides are made of sturdy aluminum extruded profiles, each one with 3 stain-free suction cups Ø 88 mm (3 1/2") - 6 suction cups in total.
- The suction cups, extremely useful while measuring the size of the cut to be made, prevent the cutting guide to move during the scoring, ensuring the maximum precision. Also, they prevent the cutting guide to overturn, no matter how much pressure is applied during the scoring: this allows to effectively score even high thickness tiles.
- The suction cups' handles perform a 180° movement in order not to interfere with the cutting unit.
- The cutting unit is made of die cast aluminum and runs onto the guide thanks to 3 polyoxymethylene (wearing-resistant material) wheels; each equipped with two internal bearings. It is provided with fine adjustment systems (factory-calibrated) allowing the perfect coupling of the cutting unit with the guide. This allows both to eliminates any kind of play and to perfectly align the wolfram-carbide cutting-wheel to the guide resulting in maximum efficacy, precision and quality of cut.
- To cut tiles thicker than 12 mm (1/2") use the pliers 169TMO1AN (accessory). Made of sturdy galvanized steel they are provided with knob to apply progressive and precise pressure exactly on the scoring line.
- The accessory extension (art. 433CRP100) offering a cutting length of 103 cm (3.4 ft.) if used alone, allows the RAIZOR system to reach a maximum length of cut of 447 cm (14.7 ft.) or 275 cm (9 ft.) by using only one profile/guide plus the extension.
- Add the cutting unit POWER-RAIZOR (accessory) to perform cuts (45°/90°/180°) with diamond disc.
- Supplied with SNAP cutting-off plier for 3-12 mm (1/8"-1/2") thickness tiles.

SPECIFICATIONS AND VERSIONS

Part No.		Description	length of cut	bag size			
433CR R	8050532001312	1 RAIZOR - complete cutting system for cutting up to 332 cm (10.9 ft.): • two connectable guides with cutting length of 160 cm (5.2 ft.) each; • die-cast cutting unit provided w/wolfram carbide wheel Ø 16 mm (5/8") and pin (pin rotates on bearings); • cutting-off pliers for tiles/slabs with thickness from 3 to 12 mm (1/8" - 1/2"); • padded bag with shoulder-straps and provided with inside modular compartments and pocket.	332 cm - 10.9'	180x25x h 16 cm - 71"x10"x h 6 3/8"	9 Kg - 19.8 lbs	186x27x h 18 cm - 73"x10 1/2"x h 7"	9,5 Kg - 21 lbs



TOOLS FOR LARGE FORMAT TILES



169TB RAI



169TM01AN



169TR01A



EXTENSION FOR RAIZOR

- Extruded aluminum extension for RAIZOR equipped with 2 stain-free-rubber suction cups Ø 88 mm (3 1/2") and connecting system. By combining the extension to both RAIZOR's guides or just one of them, the system offers the maximum flexibility in terms of length of cut (maximum 447 cm - 14.7 ft.). The extension can also be used alone (length of cut: 103 cm - 3.4 ft.). It fits in its specific compartment in RAIZOR's bag.

Part No.	Barcode	Quantity	Description	Length of cut	Weight	Dimensions	Volume	Weight
433CRP100	8050532003019	1	115 cm (3.8 ft.) extension for RAIZOR with 2 stain-free suction cups	103 cm - 40 1/2"	2,5 Kg 5.5 lbs	127x18x h 12 cm	50"x7"x h 4 3/4"	3,3 Kg 7.3 lbs

ACHIEVABLE CUTTING LENGTHS ACCORDING TO THE VARIOUS POSSIBLE COMBINATIONS OF RAIZOR + EXTENSION

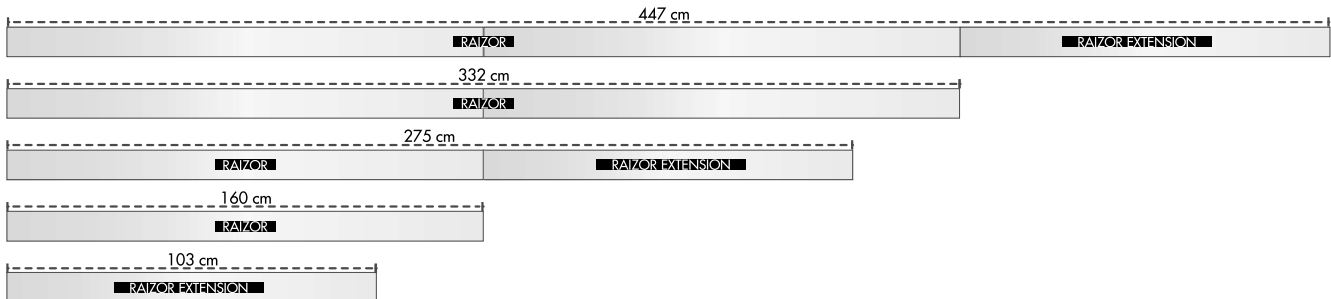

CUTTING-OFF PLIERS AND SPARE PARTS

SNAP: CUTTING-OFF PLIER FOR 3-12 mm (1/8"-1/2") THICKNESS TILES

- Cutting-off plier for tiles and slabs with a thickness from 3 to 12 mm (art. 169TB RAI).
- Body with ergonomic grip entirely made of die-cast aluminum.
- The progressive pressure applied via the special knob allows to perform the snap (in correspondence of the scoring/marking performed on the slab) with precision and extreme efficacy, while ensuring the maximum delicacy on the surface of the slab.
- Width-adjustable rubber feet maximize the load applied depending on the width of the tile.
- Compact and light (it easily fits into RAIZOR carry bag).

CUTTING-OFF PLIER FOR 6-20mm (1/4"-3/4") THICKNESS TILES

- Cutting-off pliers for tiles/slabs thicker than 6 mm - 1/4" (art. 169TM01AN).
- Made of sturdy galvanized steel.
- Provided with knob to apply progressive and precise pressure exactly on the scoring line.
- Dual position rotating presser and breaker allows to use the plier at begin/end of cut or along the strip (longitudinal/parallel to the incision/scoring).
- Width-adjustable rubber feet to fit for different widths of cut maximizes the leverage effect when applying pressure.
- Made in Italy

PLIERS AND SPARE PARTS FOR RAIZOR

Part No.	Barcode	Quantity	Description	Weight
169TB RAI	8050532008595	1	Cutting-off plier for 3-12mm (1/8"-1/2") thickness tiles (spare part)	390 gr 13.7 oz
169TM01AN	8024648067470	1	Cutting-off plier for 6-20mm (1/4"-1/2") thickness tiles	1,5 Kg 3.3 lbs
169TR01A	8024648078063	1	Cutting-off plier for tile/slab with max thickness of 6 mm (1/4")	330 gr 11.6 oz
135D16A	8024648073419	1	Wheel Ø 16 mm (5/8") with pin	10 gr 0.35 oz



POWER RAIZOR - MULTI-ANGLE CUTTING UNIT

MADE IN ITALY



433PWROH
Angle grinder not included



179CCT125



179FLEX45SERF



179FLEX45SE



179FLEX006SE

179FLEX010SE

179FLEX012SE

PACKAGE



CARTON BOX

- Multi-angle cutting unit to be used in combination to the RAIZOR cutting guide.
- It performs cuts with the following angles: 45° ("jolly", miter cut), 90° (standard/vertical cut), 180° (lateral incision - kerf/ slots along the side of the tile/slab, and/or side shaping - 1/2 bullnose).
- In addition to those positions, it also cuts at the following intermediate angles: 30°/47°/70°.
- Tilting movement (plunge cut) to adjust the depth of cut, to perform square and rectangular holes and to make cuts in multiple passes.
- Angle grinder not included.
- Suitable with the most popular brands and models of angle grinders.
- Available in 2 different versions to suit the following angle grinder arbor sizes: M14 (metric) or 5/8"-11 (imperial).
- Dry use (standard version) or wet use (to perform wet cut in combination with Kit for wet cut and dust suppression - Art. 433PWW A, Power Raizor must be equipped with cordless/battery operated angle grinder or corded model having rating IP54* or any higher).
- Includes connecting port for connection either to dust extractor or to Kit for wet cut and dust suppression (Art.433PWW A).
- Cutting depth (thickness): 20 mm (0.78") at 90°, 16 mm (0.63") at 45° and 180°.
- It comes supplied with Ø 125 mm (5") turbo blade, use and maintenance manual.

*Safety Regulations may vary from Country to Country. Therefore, it is strongly recommended to refer & comply to the legislation in force on the Country where the products is being used.

ACHIEVABLE CUTTING LENGTHS ACCORDING TO THE VARIOUS POSSIBLE COMBINATIONS OF POWER-RAIZOR AND RAIZOR + ITS EXTENSION

▼ 437 cm (14.34 ft.) | ■ 429 cm (14.07 ft.)



▼ 322 cm (10.56 ft.) | ■ 314 cm (10.3 ft.)

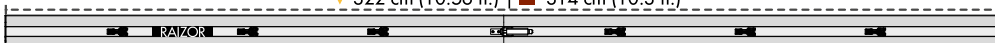

▼ 265 cm (8.69 ft.) | ■ 257 cm (8.43 ft.)

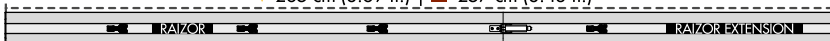

▼ 150 cm (4.92 ft.) | ■ 142 cm (4.66 ft.)



▼ 93 cm (3.05 ft.) | ■ 85 cm (2.79 ft.)



▼ plunge cut
■ no plunge cut

SPECIFICATIONS AND VERSIONS

Part No.	Box	Barcode	Description	Arbor	Disc	Grinder	Extension 1	Extension 2	Extension 3	Weight	Dimensions	Weight
433PWROHEUD	1	8050532012233	POWER RAIZOR without angle grinder	M14	•	-	20 mm 0.79"	16 mm 0.63"	16 mm 0.63"	4,1 Kg 9 lbs	39x39x h14 cm 15 3/8"x15 3/8"x h 5 1/2"	4,7 Kg 10.3 lbs
433PWROHUSD	1	8050532012240	POWER RAIZOR without angle grinder	5/8"-11	•	-	20 mm 0.79"	16 mm 0.63"	16 mm 0.63"	4,1 Kg 9 lbs	39x39x h14 cm 15 3/8"x15 3/8"x h 5 1/2"	4,7 Kg 10.3 lbs

DIAMOND BLADES AND WHEELS

Part No.	Box	Barcode	Description	Profile	Ø	Profile	Drop	Sun
179CCT125	1	8024648075703	Turbo diamond disc Ø 125 mm - 5" (f 22,2 mm) - included	-	125 mm 5"	-	•	•
179FLEX006SE	1	8024648094834	Shaping wheel for 1/2 bullnose	[Profile]	120 mm 4 3/4"	6 mm 1/4"	•	•
179FLEX010SE	1	8024648087171	Shaping wheel for 1/2 bullnose		120 mm 4 3/4"	10 mm 3/8"	•	•
179FLEX012SE	1	8050532010970	Shaping wheel for 1/2 bullnose	[Profile]	120 mm 4 3/4"	12 mm 1/2"	•	•
179FLEX45SE	1	8050532010987	Shaping wheel for 45° profile (jolly)		120 mm 4 3/4"	-	•	•
179FLEX45SERF	1	8050532011267	Finishing wheel for 45° profile (jolly)	120 mm 4 3/4"	-	•	•	



TOOLS FOR LARGE FORMAT TILES



433BCOH
Angle grinder not included



179CCT125



179CCL115

PACKAGE



- Device to perform 45° miter cut high quality finishing ("jolly") directly on construction site (actual miter angle: 47°).
- It works leaning and sliding on the edge of the tile (or slab): this guarantees a fast and precise work execution and allows to work without any limit on length.
- The anti-scratch plastic slides ensure optimal smoothness on the slab/tile.
- Maximum slab/tile thickness: 16 mm (0.63") with Ø115 mm (4 1/2") blade; 20 mm (0.79") with Ø125 mm (5") blade.
- The two handles are designed to easily allow the necessary pressure during the entire length of the miter cut (entrance, slab side, exit) to guarantee both optimal results and maximum ergonomics.
- Cutting depth adjustment: by adjusting the dedicated knobs, it is possible to determine the amount of material to be removed (farther or closer to tile glaze). Once the adjustment is set, it stays for any tiles/slabs thicknesses.

- Blade tilt adjustment: by acting onto dedicated screw, blade can be tilted to prevent its rear chipping the edge of tiles/slabs.
- Suitable with almost all angle grinders with power between 600-1100W.
- Available for grinders with M14 arbor attachment (art. 433BCOH EU) and for angle grinders with 5/8" - 11 arbor attachment (art. 433BCOH US).
- It can be either used dry (with a dust extractor) or with water (with kit for wet cut art.433PWW A).
- It comes supplied with: Ø 115 (4 1/2") "Cross-Turbo" blade, use and maintenance manual.

SPECIFICATIONS AND VERSIONS

Part No.			Description							
433BCOH EU	1	8050532012134	BC45 - Device to perform 45° miter cut high quality finishing ("Jolly")	M14	•	—	Disc Ø 115 mm 16 mm - 0.63"	3,9 Kg 85.9 lbs	31x27x h 13 cm	4,3 Kg 9.5 lbs
433BCOH US	1	8050532012141		5/8"-11	•	—	Disc Ø 125 mm 20 mm - 0.79"	3,9 Kg 85.9 lbs		12 1/4"x10 5/8"x h 5 1/8"

DIAMOND BLADES

Part No.			Description	Ø			
179CCL115	1	8050532012110	Diamond disc "Cross" (f 22,2 mm) - included	115 mm	4 1/2"	•	•
179CCT125	1	8024648075703	Turbo diamond disc Ø 125 mm - 5" (f 22,2 mm)	125 mm	5"	•	•

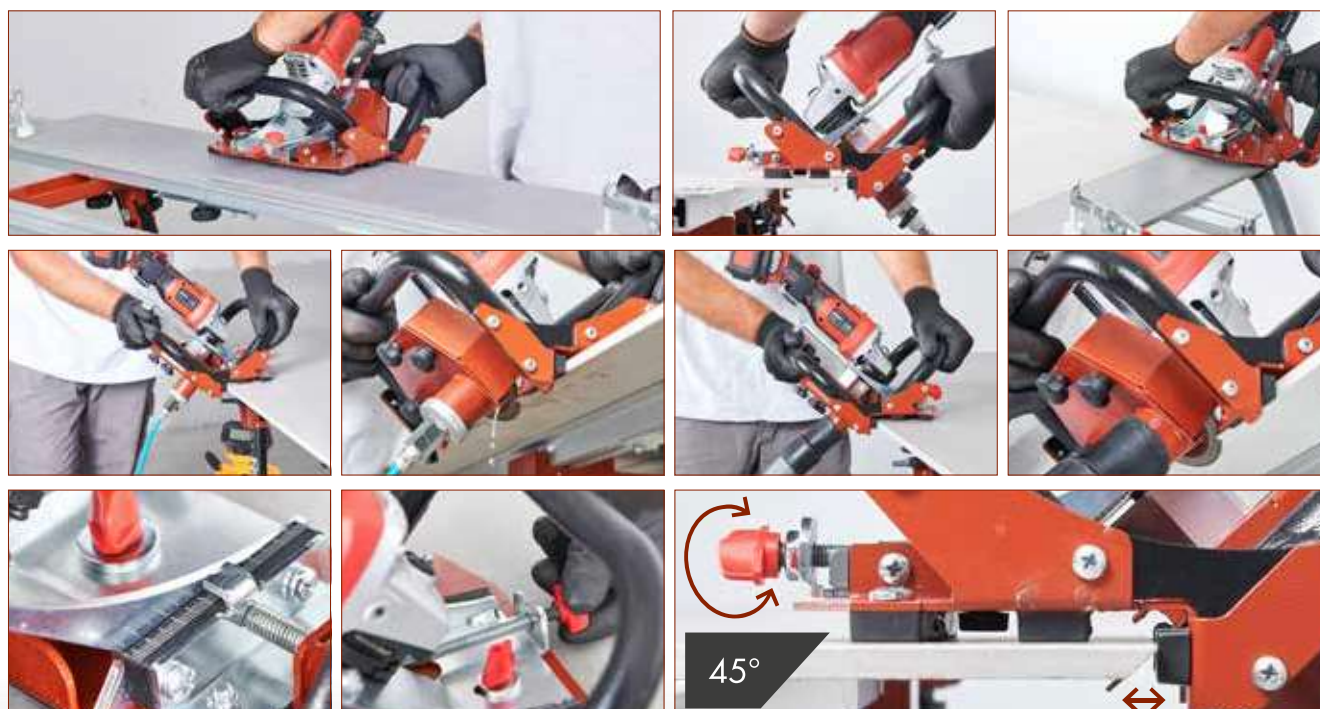

TOOLS FOR LARGE FORMAT TILES



KIT FOR WET CUT AND DUST SUPPRESSION

- Wet cooling device to be used in combination with POWER RAIZOR and BC45.
- Blade cooling with water grants:
 - 1) Complete suppression of dust.
 - 2) Better cut finishing.
 - 3) Quicker cut.
- Both adjustments onto top and onto spraying nozzle allow a perfect cooling with a minimal amount of water.

- To be used only in combination with cordless (battery operated) angle grinders and/or corded models having rating IP 54* or any higher.
- It can be used with any cutting position/angle (45°/90°/180°).
- Carrytank capacity of 8 litres (1,75 gal) with relief valve.

*Safety Regulations may vary from Country to Country. Therefore, it is strongly recommended to refer & comply to the legislation in force on the Country where the products is being used.

SPECIFICATIONS AND VERSIONS

Part No.			Description	POWER RAIZOR	BC45	USE					
433PWZP A	1	8050532004573	Kit for wet cut and dust suppression	•	•	e/o	8 lt	1,75 gal	2,4 Kg	5.3 lbs	58x30x h25 cm 23"x12"x h 10"

DUST CONTAINMENT DEVICE

- Dust containment device to be used in combination with POWER RAIZOR cutting unit.
- Used in combination with a proper aspirator, it allows to radically reduce the amount of dust on the environment while dry cut is performed.
- The device can be used onto POWER RAIZOR equipped with any kind of angle grinder.

- Adjustable according with slab thickness.
- Can be used for 45° miter cut and 90° straight cut.

SPECIFICATIONS AND VERSIONS

Part No.			Description	POWER RAIZOR	BC45	USE				
433PWZP A	1	8050532004412	Dust containment device	•	–	All angle grinders	0,5 Kg	1.1 lbs	27x15x h10 cm	10 5/8"x6"x h 4"

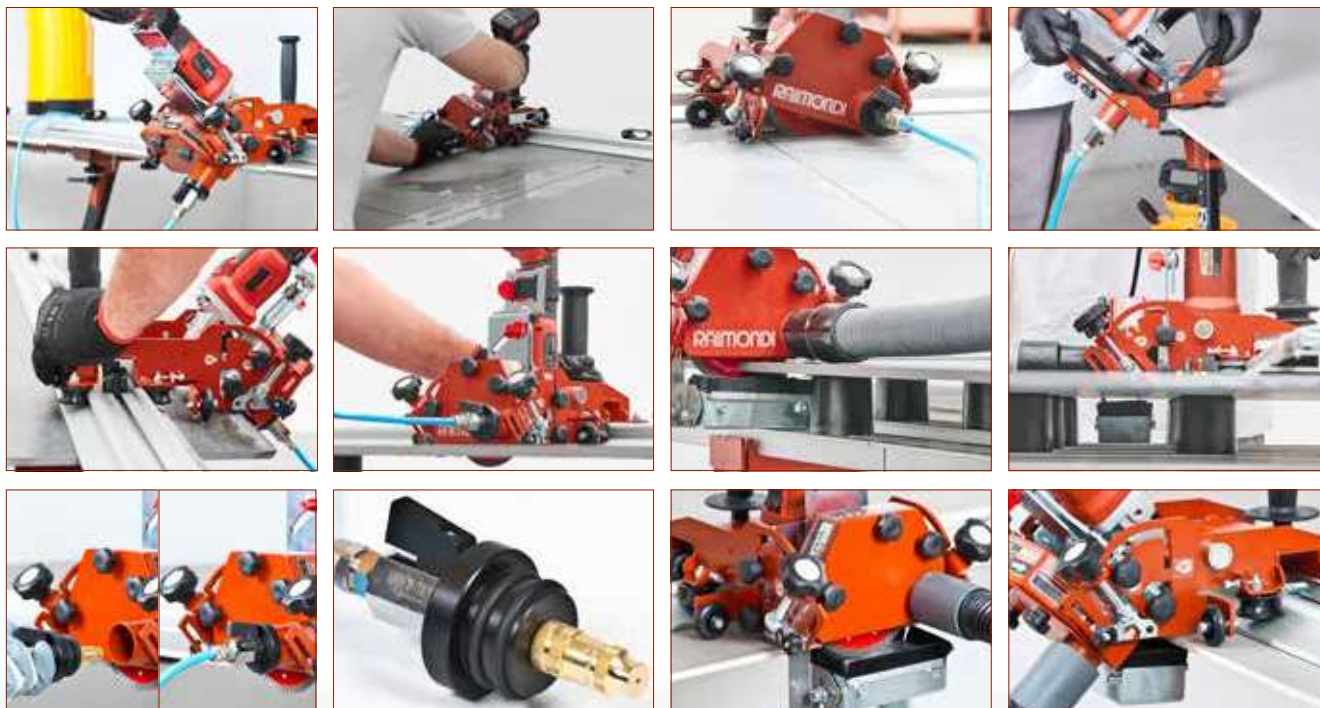

MADE IN ITALY

CE MARKED

PATENTED

YouTube

VIDEO ON YOUTUBE



433TC RAI

PACKAGE



CARTON BOX

- Device for score cutting porcelain slabs.
- Extremely light (1.7 Kg) and very low dimensions. Excellent portability.
- For the execution of the incision, the device can be used by placing the wheels on the edge of the tile (for parallel cuts) or, alternatively, at the edge of the workbench (for diagonal cuts). To perform the incision, keep the T-CUT running onto edge and slide it sideways along the entire length of the slab while simultaneously pushing down onto scoring knob unit.
- Achievable cutting width with T-CUT running onto edge of the slab: minimum 40 mm, maximum 600 mm (min 1 2/3" - MAX 23 5/8").
- Achievable cutting width with T-CUT running onto edge of the workbench: minimum 0 mm, maximum 550 mm (min 0" - MAX 21 2/3").
- Unlimited cutting length.
- Incision wheel Ø 16 mm (5/8") mounted on a hardened steel pin with two ball bearings.
- Metric / Imperial ruler showing the cutting width. Easy to regulate.
- Supplied with cutting-off plier for slabs with 3-12mm (1/8"-1/2") thickness. Ensures a progressive pressure.
- The body is equipped with 5 wheels to allow an accurate incision on the entire length of the tile, especially on entering and exiting (start & end incision).

SPECIFICATIONS AND VERSIONS

Part No.	Barcode	Carton	Description	Achievable tile/slab width				Weight	Dimensions	Net Weight
				on edge of the slab		on edge of the workbench				
433TC RAI	8050532022102	1	T-CUT device for scoring and cutting large format tiles	min 40 mm MAX 600 mm	min 1 2/3" MAX 23 5/8"	min 0 mm MAX 550 mm	min 0" MAX 21 2/3"	2,1 Kg 4.6 lbs	71x23xh 12 cm 28"x9 1/16"xh 4 2/8"	2,5 Kg 5.5 lbs

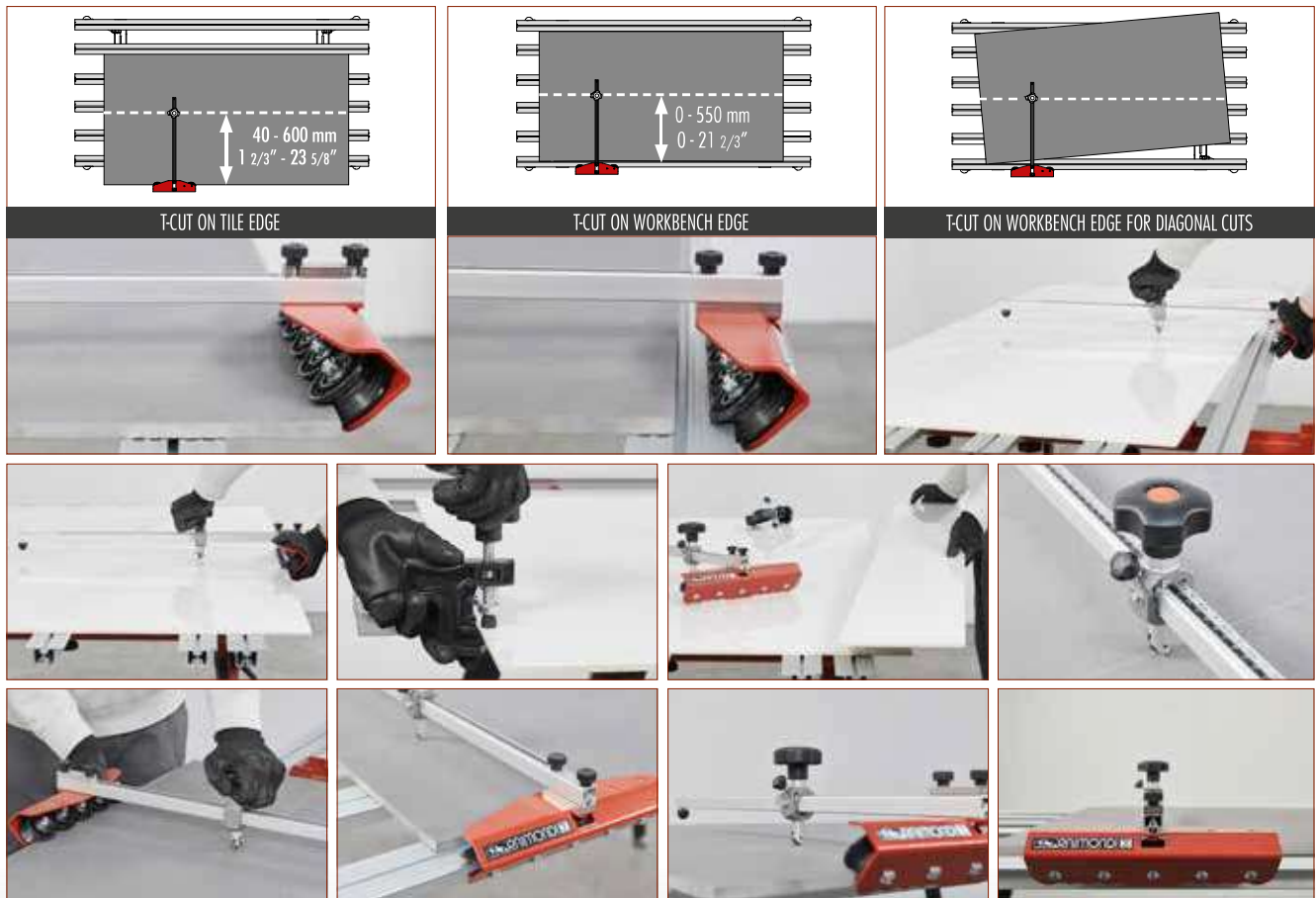

TOOLS FOR LARGE FORMAT TILES

BM 180^{PLUS} - ADJUSTABLE WIDTH (100-150 cm / 3.3'- 5') TABLE



"BM 180 PLUS" with folding legs/transport position



min: 100 cm
max: 150 cm

394MA PLUS

PACKAGE



2 "BM 180 PLUS" combined



Worktop dim: 360x100 cm

2 "BM 180 PLUS" combined



Worktop dim: 360x150 cm

- BM 180^{PLUS} is a variable width table designed to be the perfect workstation for large format tiles up to 160 cm (5.3') and to be easy to transport.
- With few simple movements, the width of the worktop can vary from a minimum of 100 cm (3.3') to a maximum of 150 cm (5') with intermediate steps.
- In order to obtain an optimal worktop for any chosen width, the aluminum profiles are easily movable.
- When changing the width of the table the legs move as well, therefore they always maintain the optimal position to guarantee the maximum stability and strength of the bench at any chosen width.
- The length of the top is 180 cm (5.9'). Connect two tables together to obtain a worktop of 360 cm (11.8') in length (and variable with from 100 to 150 cm – 3.3' to 5'). This feature makes the BM 180^{PLUS} the perfect workstation for slabs of any size.
- When in minimum width position, the bench is compact and easy to transport and store. Its folding legs make it even more practical.
- Being the anodized aluminum profiles (which make up the worktop) spaced and movable, it is

- possible to perform cuts with angle grinder and diamond blade without damaging them. Moreover, the special tile-support-cylinders (available as an accessory) create a gap between the tile and the worktop allowing to perform cuts with angle grinders in every direction without damaging the bench.
- Legs provided with adjustable feet for perfect leveling of the bench.
- The steel structure and the worktop made of anodized aluminum profiles assure maximum strength and stability.
- It possible to eventually add extra aluminum profiles (accessory).
- Main important specifications:
 - Width: variable/adjustable from 100 to 150 cm (from 3.3' up to 5');
 - Length: 1 bench 180 cm (5.9'); 2 benches combined 360 cm (11.8');
 - Height of the worktop from the ground: 83 cm (32 3/4');
 - Maximum load capacity: 150 Kg (331 lbs).
 - Wide range of accessories available.

SPECIFICATIONS AND VERSIONS

Part No.		Description					
394MA PLUS	8050532007062	1 BM 180 ^{PLUS} adjustable width (100-150 cm / 3.3'- 5') table for large format tiles	38 Kg	83.7 lbs	190x21x h 10 cm + 117x20x h 20 cm	75"x 8 1/4"x 3 1/2" + 46"x8"xh 8"	39,6 Kg 87,3 lbs

ACHIEVABLE WORKTOP DIMENSIONS WITH TWO BM 180^{PLUS} BENCHES ONLY

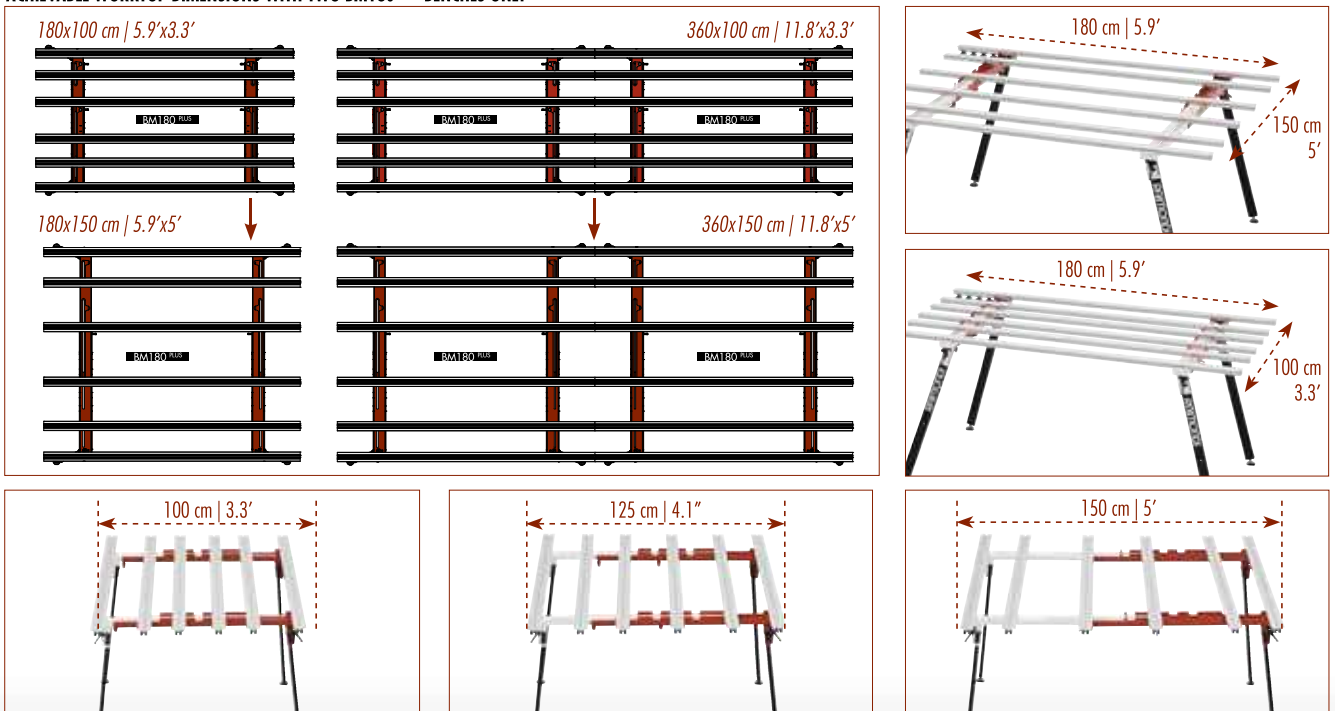

TOOLS FOR LARGE FORMAT TILES



394MA RAI

PACKAGE



"BM180^{MkII}" with folding legs/transport position



2 "BM180^{MkII}" combined



- BM180^{MkII} is the ideal table for cutting and processing large format slabs.
- Worktop dimensions: single table 180 x 90 cm (3'x6'); two combined tables 360x90 cm (11.8'x2.9').
- Thanks to the range of dedicated extensions (accessories) and the possibility to combine two BM180^{MkII} together, the worktop can extend up to 420 cm (13.8') or even more if needed, passing through intermediate measures such as 360 cm (11.8'), 270 cm (8.9') and 240 cm (7.9'). Width can reach up to 150 cm. All these combinations make the BM180^{MkII} perfect for tiles of any dimension.
- Being the anodized aluminum profiles (which make up the worktop) spaced and movable, it is possible to perform cuts with angle grinder and diamond blade without damaging them. Moreover, the special tile-support-cylinders (available as an accessory) create a gap between the tile and the

- worktop allowing to perform cuts with angle grinders in every direction without damaging the bench.
- Legs provided with adjustable feet for perfect leveling of the bench.
- The steel structure and the worktop made of anodized aluminum profiles assure maximum strength and stability.
- Height: 83 cm (32 3/4"). Maximum load capacity (single table): 150 Kg (331 lbs.).
- Wide range of dedicated accessories available.

SPECIFICATIONS AND VERSIONS

Part No.		Description			
394MA RAI	805053200995	1 BM180 ^{MkII} modular bench with folding legs	29 Kg / 63.9 lbs	190x21x h 10 cm + 117x20x h 20 cm	75"x 8 1/4" x 3 1/2" + 46"x8" x h 8"



180x90 cm | 5.9'x3'



360x90 cm | 11.8'x3'

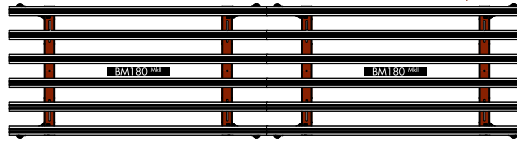

EXTENSIONS FOR MODULAR TABLE BM180 ^{MkII} AND BM180 ^{PLUS}

MADE IN ITALY



394CP270A



394CP270A PLUS

min: 100 cm
max: 150 cm



394EST 01A

"BM180 PLUS" with extension 394CP270A PLUS



PACKAGE



CARTON BOX

SPECIFICATIONS AND VERSIONS

Part No.	Barcode	Description	BM180 MkII	BM180 PLUS	Weight	Dimensions	Package Dimensions	Weight
394CP270A	8050532005136	Side extension complete w/6 aluminum profiles and folding legs to lengthen the bench of 90 cm (35 1/2") - tot. 270 cm (8.9')	•	–	11,6 Kg / 25.6 lbs	117x20x h20 cm	46"x8"x h 8"	12,5 Kg / 27.5 lbs
394CP270A PLUS	8050532000599	Telescopic extension (100-150 cm) to lengthen the bench of 90 cm (35 1/2") - tot. 270 cm (8.9')	–	•	6,2 Kg / 13.7 lbs	140x14xh 8 cm	55 1/8"x 5 1/2" xh 3"	7,2 Kg / 15.9 lbs
394EST 01A	8050532000124	Telescopic extension to widen the bench up to 60cm - 23 5/8" (tot. width 150 cm - 4.9')	•	–	8,2 Kg / 18.1 lbs	190x Ø17 cm	46" x Ø 8"	10,2 Kg / 22.5 lbs

ACHIEVABLE WORKTOP DIMENSIONS WITH TWO BM180 ^{MkII} AND EXTENSIONS

EXAMPLE OF ACHIEVABLE WORKTOP DIMENSIONS WITH BM180 ^{PLUS} AND EXTENSION

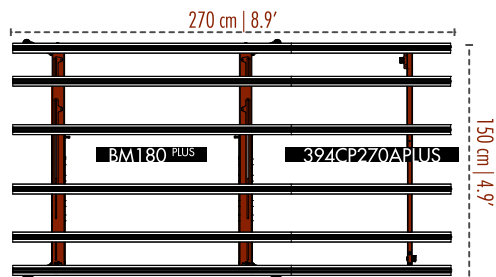
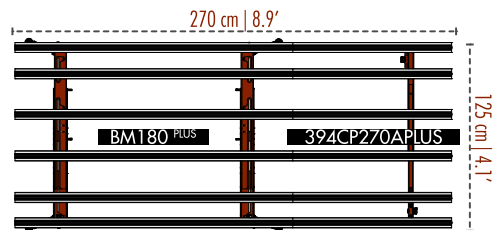
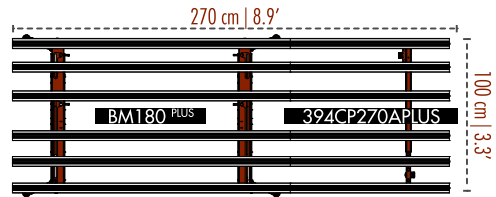
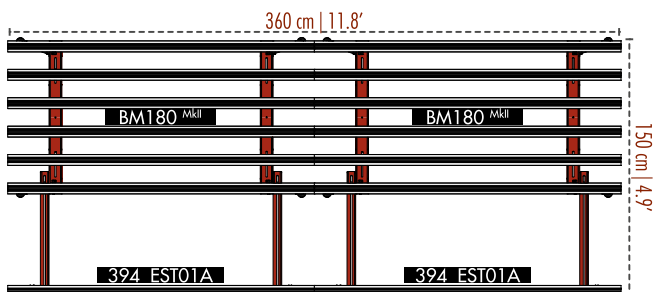
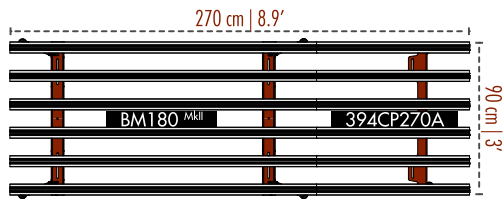
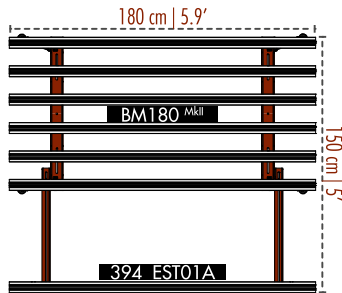

TOOLS FOR LARGE FORMAT TILES



1x BM180 ^{MkII} + 2x 394EST 01A
Worktop dim: 360x150 cm



1x BM180 ^{MkII} + 1x 394CP270A
Worktop dim: 270x90 cm

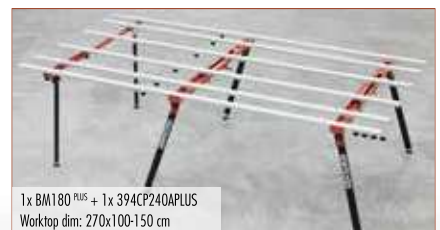

1x BM180 ^{PLUS} + 1x 394CP270A PLUS
Worktop dim: 270x100-150 cm



"TSE180" with folding legs/transport position.



"TSE180" mounted on 2 "BM180 PLUS" combined.



"TSE180" mounted on 1 "BM180 PLUS".

PACKAGE



CARTON BOX

- The new lateral tilting extension supports the tile and facilitates splitting after scoring during the cutting process. It also prevents the cut portion from falling.
- The device allows the support of the tile both during and after the splitting phase.
- Splitting can be performed by one single operator.
- Extremely easy to be installed/removed either on a single or on multiple workbenches connected together
- Whenever not in use, it can be completely tilted down below the workbench.
- Legs are equipped with adjustable feet for a perfect alignment with the workbench.
- Anodized aluminum profiles with adjustable position to optimize the worktop
- Fully suitable with both BM180MKII and BM180PLUS workbenches.

SPECIFICATIONS AND VERSIONS

Part No.	Barcode	Carton	Description	Weight	Dimensions	Volume
394RB RAI	8050532024038	1	TSE180 – lateral tilting extension for BM180 MKII e BM180 PLUS	18,8 Kg 41.44 lbs	186x27xh 18 cm 73"x10 5/8"xh 7"	21,5 Kg 47.39 lbs

POSSIBLE COMBINATION WITH BM180 BENCHES

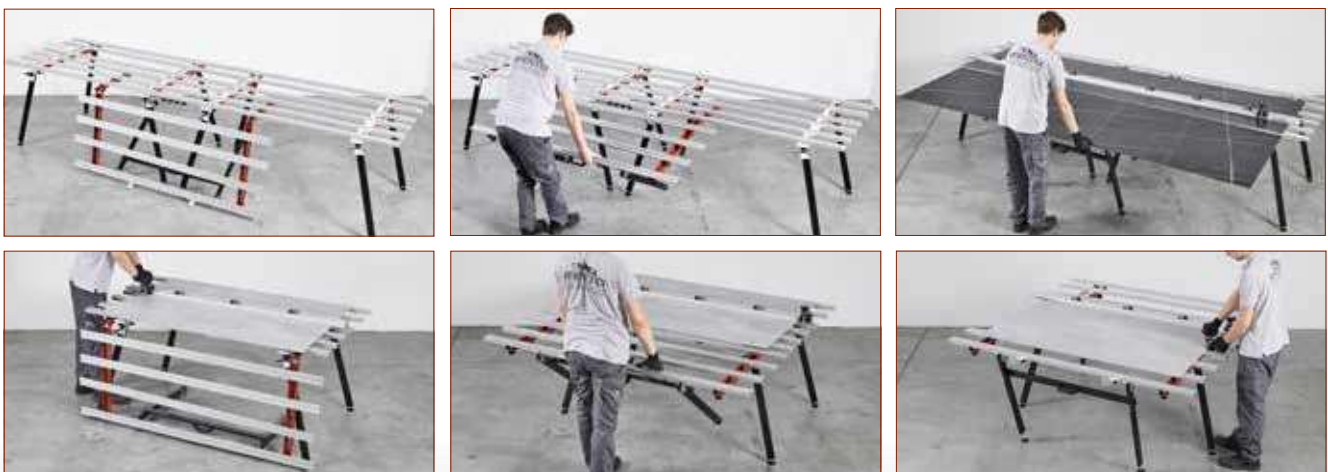
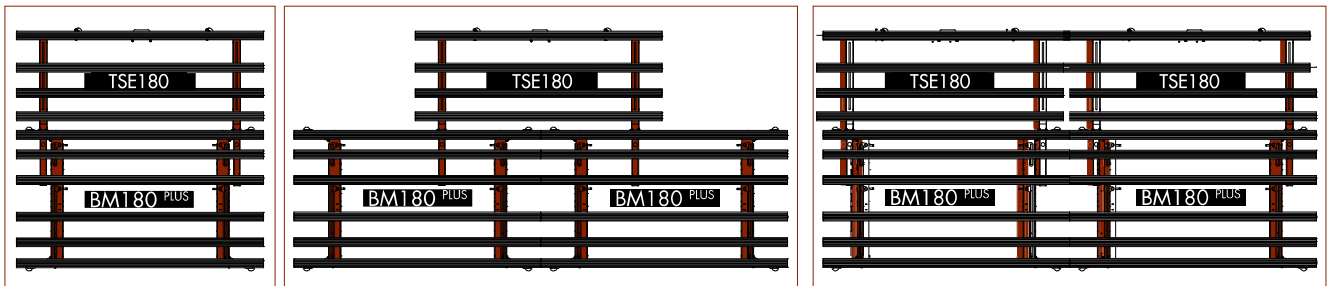

TOOLS FOR LARGE FORMAT TILES

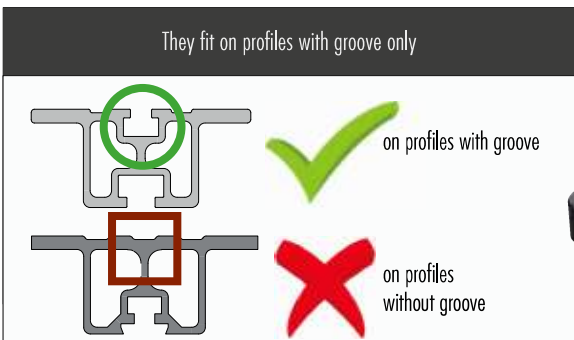

PACKAGE



KIT OF 20 TILE-SUPPORT CYLINDERS TO PERFORM CUT WITH ANGLE GRINDER ON BM180^{MkII} AND BM180^{PLUS} TABLES

- To perform with ease cuts with angle grinder (even l-shaped and/or squares holes) on tiles up to 160x320 cm (5.3'x11.9') in any direction.
- One kit consists of 20 polypropylene supports (h56 mm - Ø 60 mm | h2.2" - Ø 2.4") that once inserted along the aluminum profiles, supports the tile and creates a gap between it and the worktop. This allows to perform cuts with angle grinders in any direction without damaging the bench.
- The possibility to freely positioning the cylinders at any point on the worktop allows to choose their layout according to the tile dimension and the kind of cut to be done. Even in the most difficult situations and for the most complex cuts.
- Inserting and fixing is extremely easy and fast: just insert the screw underneath each cylinder into the dedicated slot of each aluminum profiles (which made up the worktop) and slide the supports in the desired position. Slightly rotate the cylinders to fix them.
- Its design and the premium quality polymer they are built with make the cylinders extremely sturdy. They are designed to support tiles of any weight and to last potentially forever.
- The supports are compatible with both BM180^{MkII} and BM180^{PLUS} as well as previous versions if equipped with top-grooved aluminum profiles.
- The supports do not preclude the use of the wide range of accessories dedicated to BM180 tables nor the use of POWER-RAIZOR both in combination with water-cut kit (Art.433PWVA) and/or the dust suppression device for dry cut (Art.433PWZPA).

SPECIFICATIONS AND VERSIONS KIT TILE-SUPPORT CYLINDERS

Part No.	Barcode	Box	Description	BM180 MkII	BM180 PLUS	USE	Weight	Dimensions	Volume
394CC 01A	8050532004207	1	Kit of 20 tile-support cylinders for BM180 ^{MkII} and BM180 ^{PLUS}	•	•	on profiles with groove	0,9 Kg 1.9 lbs	39x39xh 15 cm 15 3/4"x15 3/4"x h 6"	1,2 Kg 2.8 lbs

SIDE PROFILES FOR SCORING AND CUT

- The side profile connects to the short side of the table offering a continuous support for score & cut the short side of the tile (i.e.: cut 120 cm side of a 120x240 cm tile).
- Available in two lengths: 124 cm and 164 cm (4' and 5.4'). Therefore, suitable even for the largest tiles.
- We recommend the use of the 164 cm (5.4') version only with BM180^{PLUS}.
- Version 124 cm (4') fits on both BM180^{MkII} and BM180^{PLUS}.
- Free to slide in and out when mounted so to not interfere with operator when doesn't need them.

SPECIFICATIONS AND VERSIONS FOR SIDE PROFILES FOR SCORING AND CUT

Part No.	Barcode	Box	Description	BM180 MkII	BM180 PLUS	Weight	Dimensions	Volume
394IS 1200	8050532007024	1	Side profiles for scoring and cut length 124 cm (4')	•	•	-	-	-
394IS 1600	8050532007031	1	Side profiles for scoring and cut length 164 cm (5.4')	-	•	-	-	-

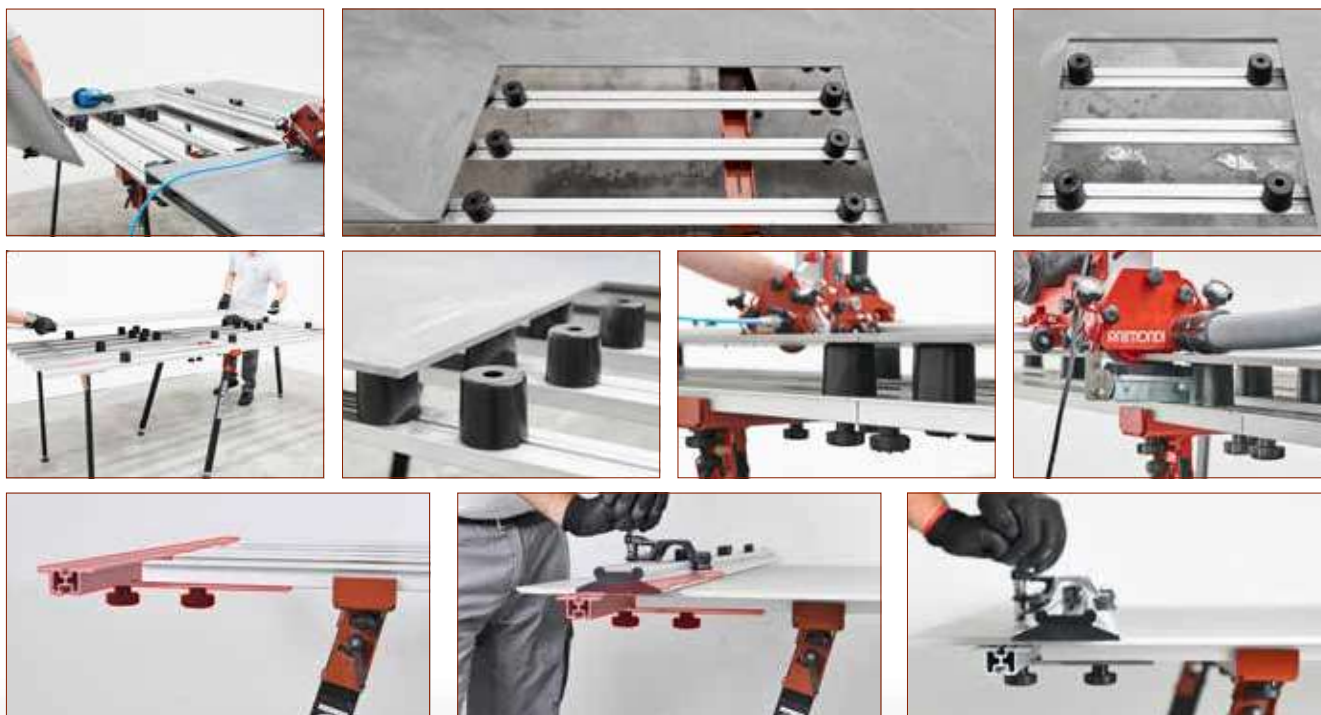

TOOLS FOR LARGE FORMAT TILES

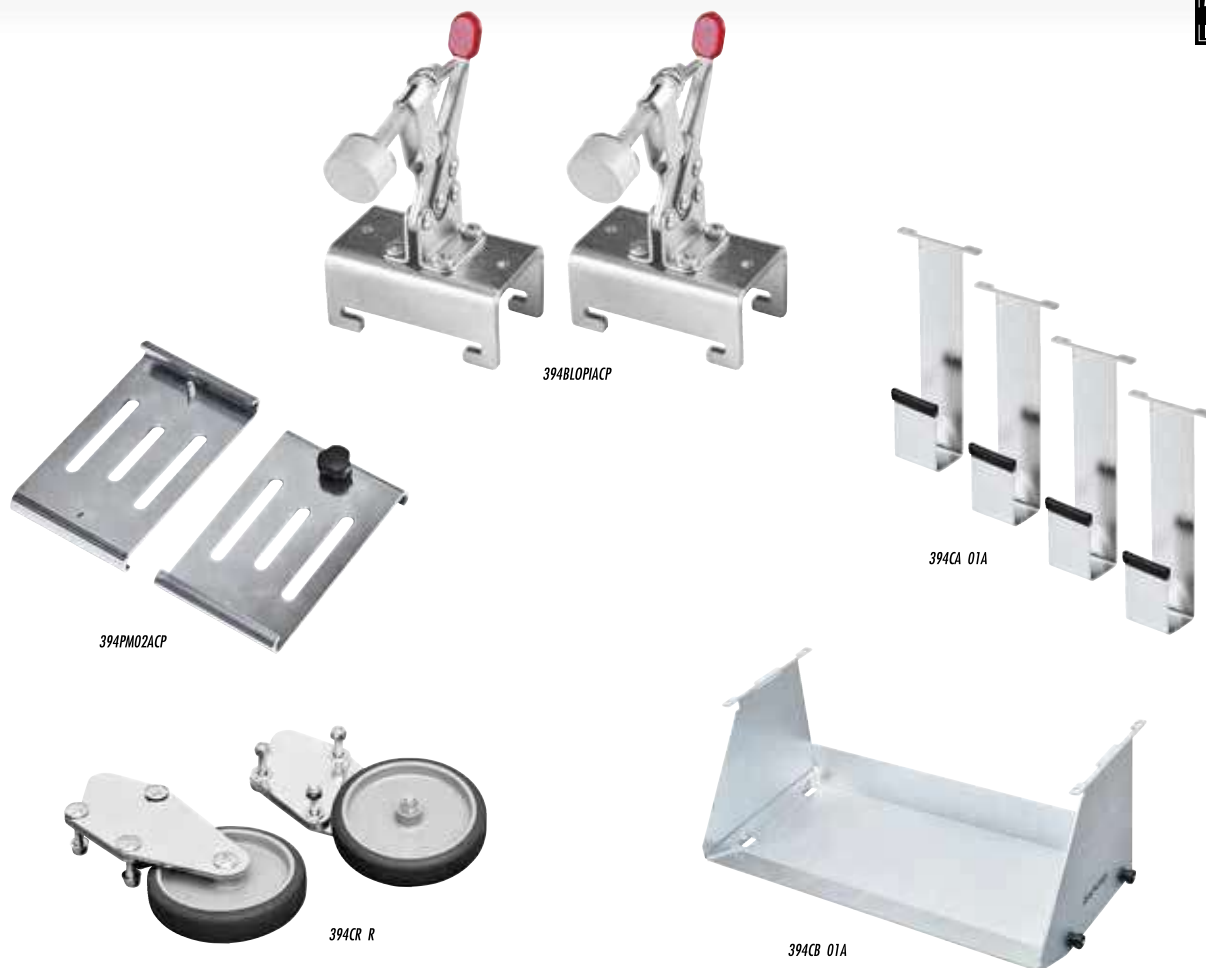

SPECIFICATIONS AND VERSIONS

Part No.	Barcode	Box	Description	BM180 MkII	BM180 PLUS	Weight	Volume	Dimensions	Weight	Volume	
394BLOIACP	8024648096678	1	Stand-alone tile holder (for 3 to 30 mm thicknesses) - pair	•	•	0,9 Kg	2 lbs	27x15xh 10 cm	10 5/8" x 4" xh 6"	1 Kg	2.2 lbs
394PM02ACP	8024648096722	1	Strips support - pair	•	•	0,6 Kg	1.3 lbs	27x15xh 10 cm	10 5/8" x 4" xh 6"	0,7 Kg	1.5 lbs
394CR R	8050532000940	1	Wheels for legs - pair	•	•	1,7 Kg	3.7 lbs	27x15xh 10 cm	10 5/8" x 4" xh 6"	1,8 Kg	4 lbs
394CA 01A	8050532002364	1	Kit of 4 lateral steel hooks for hang up the cutting guides	•	•	0,5 Kg	1.1 lbs	37x17xh 8 cm	13" x 6 5/8" xh 3"	2 Kg	4.4 lbs
394CB 01A	8050532002388	1	Steel-made side tools box	•	-	4.9 Kg	10.8 lbs	58x28xh 23 cm	23" x 11" xh 9"	5,4 Kg	11.9 lbs

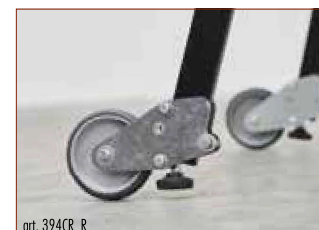

EASY-MOVE ^{MkIV} WITH DOUBLE SUCTION CUPS^{PLUS}

MADE IN ITALY

ANTIMACCHIA STAIN FREE SUCTION CUPS

UPGRADE

PATENTED

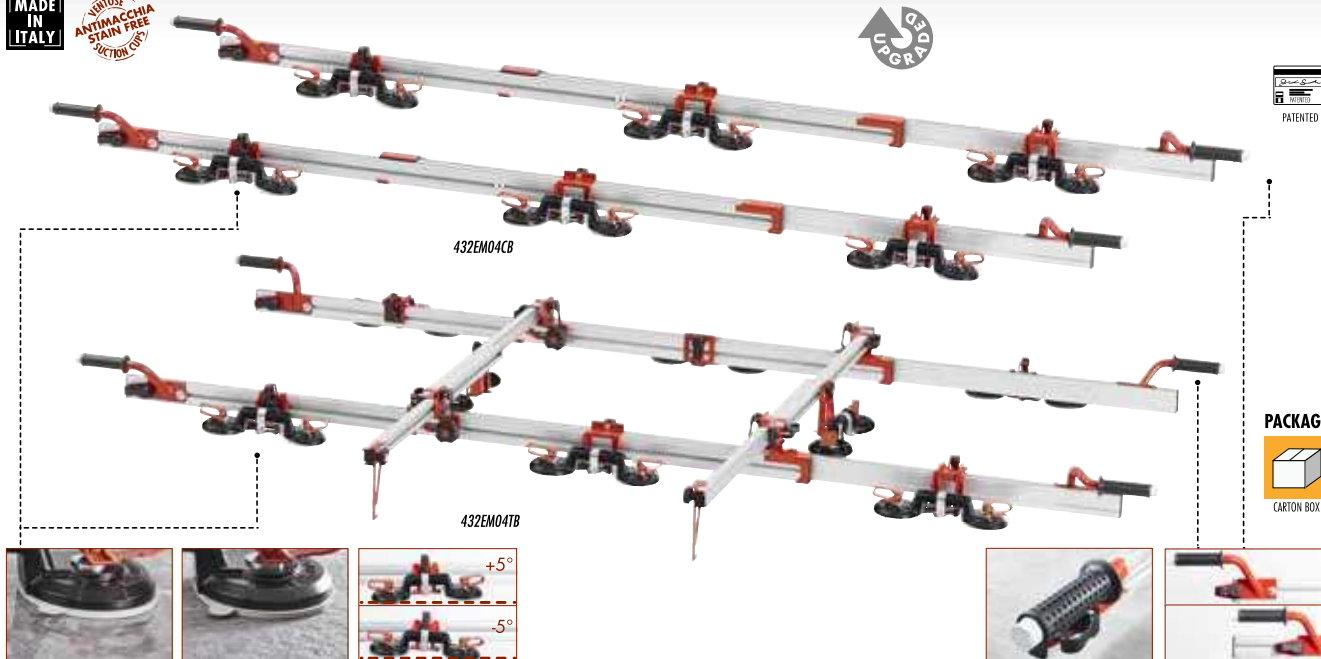

EASY-MOVE ^{MkIV} WITH DOUBLE SUCTION CUPS^{PLUS}

- Completely redesigned this 4th generation of Easy-Move frame for handling large format tiles offers functionality and performance never achieved before.
- Weight reduced by over 19% compared to the previous version.
- Equipped with double suction cups PLUS with stain-free-rubber, ideal for both smooth and textured tile.
- The sliding between the main aluminum profiles is extremely fluid thanks to the anti-friction pads.
- All suction cups (including the central ones) can be easily slid into any position along the profiles.
- Available version with two variable-length telescopic crossbars (mini 90 cm / 35 1/2"; max 160 cm / 63") to allow easy entry into the case/skid and adapt to slabs of any width.
- Crossbars can be easily tilted at an angle (compared to the main profiles) so to adapt to even the most complicated slab layouts.
- Each crossbar is equipped with a double suction cup that can be moved along its entire length. The suction cup can be positioned both inside and outside the main profiles quickly and easily.
- All sliding and movements are extremely fluid to quickly and easily adapt the frame configuration to the slab layout. Even the most complicated.
- Tilting suction cups (+/- 5°) to adapt to the inevitable bending of the slabs and guarantee the perfect grip in every situation.

- Suction cups are all positioned in line so to allow using EASY-MOVE ^{MkIV} also on reduced width slabs (minimum width 14 cm / 5 1/2").
- The 4 sliding handles provided with non-slip and stain-proof grommet result in best ergonomics and handling even for wall installation. Each handle equipped with soft rubber grip.
- Maximum slab length 320 cm (10.5 feet); minimum 100 cm (3.3 feet).
- Available version with crossbars (8 double suction cups PLUS) or without (6 double suction cups PLUS). Pair of crossbars and their suction cups also available as accessory.
- Available as accessory the kit of 4 double handles to maximize ergonomics in case of use by 4 operators.
- Equipped with use and maintenance manual.

SPECIFICATIONS AND VERSIONS

Part No.	Barcode	Quantity	Description	Weight	Dimensions	Volume	Weight
432EM04CB	8050532010529	1	EASY-MOVE ^{MkIV} with 6 double suction cups (Biventosa ^{PLUS} with stain free rubber)	17,3 Kg 38.1 lbs	180x 37xh 30 cm	71"x 14"xh 12"	21,1 Kg 46.5 lbs
432EM04TB	8050532010567	1	EASY-MOVE ^{MkIV} with 8 double suction cups (Biventosa ^{PLUS} with stain free rubber)	25 Kg 55.1 lbs	180x 37xh 30 cm+ 101x12x h15 cm + 37x19x h 17 cm	71"x 14"xh 12"+ 40"x5"x6"+ 14"x7 1/2"xh 7"	30 Kg 66.1 lbs



TOOLS FOR LARGE FORMAT TILES

EASY-MOVE ^{MkIV} WITH RV175 SUCTION CUPS (VACUUM WITH GAUGE)

VERTICE
ANTIMACCHIA
STAIN FREE
SUCTION CUPS

MADE
IN
ITALY

PATENTED



EASY-MOVE ^{MkIV} WITH RV175 SUCTION CUPS (VACUUM WITH GAUGE)

- Completely redesigned this 4th generation of Easy-Move frame for handling large format tiles offers functionality and performance never achieved before.
- Weight reduced by over 25% compared to the previous version.
- Equipped with the innovative RV175 vacuum suction cups (perfect for textured tiles) featuring vacuum gauge and stain-free rubber, both very easy to replace in case of need, and die-cast aluminum body.
- Maximum safety thanks to the vacuum gauges (placed in protected position) which constantly indicates the degree of vacuum inside the cup. The pump system allows to restore/increase the vacuum at any time with the suction cup still in place/working.
- The sliding between the main aluminum profiles is extremely fluid thanks to the anti-friction pads.
- All suction cups (including the central ones) can be easily slid into any position along the profiles.
- Available version with two variable-length telescopic crossbars (mini 90 cm / 35 1/2"; max 160 cm / 63") to allow easy entry into the case/skid and adapt to slabs of any width.
- Crossbars can be easily tilted at an angle (compared to the main profiles) so to adapt to even the most complicated slab layouts.
- Each crossbar is equipped with a RV175 suction cup that can be moved along its entire length. The suction cup can be positioned both inside and outside the main profiles quickly and easily.
- All sliding and movements are extremely fluid to quickly and easily adapt the frame configuration to the slab layout. Even the most complicated.
- Tilting suction cups (+/- 5 °) to adapt to the inevitable bending of the slabs and guarantee the perfect grip in every situation. The system is particularly useful for textured slabs.
- Suction cups are all positioned in line so to allow using EASY-MOVE ^{MkIV} also on reduced width slabs (minimum width 19 cm / 7 1/2").
- The 4 sliding handles provided with non-slip and stain-proof grommet result in best ergonomics and handling even for wall installation. Each handle equipped with soft rubber grip.
- Maximum slab length 320 cm (10.5 feet); minimum 100 cm (3.3 feet).
- Available version with crossbars (8 suction cups) or without (6 suction cups). Pair of crossbars and their suction cups also available as accessory.
- Available as accessory the kit of 4 double handles to maximize ergonomics in case of use by 4 operators.
- Equipped with plastic suction cups protections, use and maintenance manual.

SPECIFICATIONS AND VERSIONS

Part No.	Barcode	Box Icon	Description	Weight Icon	Weight	Dimensions Icon	Dimensions	Weight Icon	Weight
432EM04CA	8050532010512	1	EASY-MOVE ^{MkIV} with 6 vacuum (pump) suction cups "RV175" with vacuum gauge (stain-free-rubber)	16,5 Kg	36.3 lbs	180x 37xh 30 cm	71" x 14" xh 12"	20,3 Kg	44.7 lbs
432EM04TA	8050532010550	1	EASY-MOVE ^{MkIV} with crossbars with 8 vacuum (pump) suction cups "RV175" with vacuum gauge (stain-free-rubber)	23,9 Kg	52.6 lbs	180x 37xh 30 cm+ 101x12xh 15 cm + 37x19x h 17 cm	71" x 14" xh 12"+ 40" x 5" x 6"+ 14" x 7 1/2" xh 7"	28,8 Kg	63,5 lbs

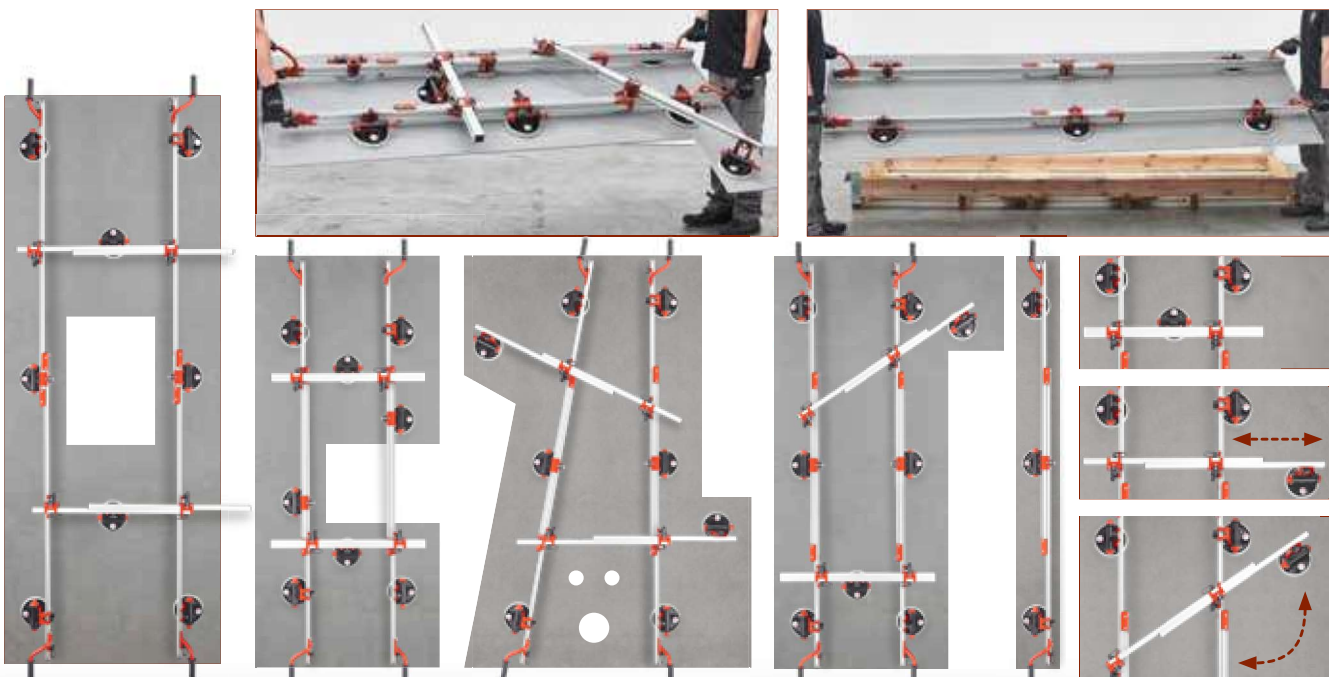

TOOLS FOR LARGE FORMAT TILES

EASY-MOVE 150 WITH RV175 SUCTION CUPS (VACUUM WITH GAUGE)

MADE IN ITALY

VENTILATE
ANTIRIFLESSO
STAIN FREE
SUCTION CUP



PACKAGE
CARTON BOX

- Pair of handling devices for tiles/slabs up to 150 cm (4.9') long.
- Fixed length aluminum profiles.
- Equipped with 4 "RV175" vacuum suction cups (2 on each profile), perfect also for textured tiles/slabs.
- "RV175" vacuum suction cups (with die-cast aluminum body) feature vacuum gauge and stainfree rubber, both very easy to replace in case of need, as well as a corrosion-resistant vacuum valve;
- Maximum safety thanks to the vacuum gauges (placed in protected position) which constantly indicate the vacuum level inside the cup. The pump system allows to restore/increase the vacuum level at any time with the suction cup engaged.
- Each vacuum suction cup can be easily repositioned along the entire length of the aluminum bars;

- Tilting suction cups (+/- 5°) to adapt to the eventual bending of the slab and to guarantee the perfect grip in every situation. This feature is particularly useful for textured slabs.
- Suction cups are all positioned in line so to allow using EASY-MOVE 150 also on reduced width slabs (minimum width 19 cm / 7 1/2").
- The 4 sliding handles provided with non-slip and stain-proof grommet result in best ergonomics and handling even for wall installation. Each handle is equipped with soft rubber grip.
- It can be used in combination with EASY-MOVEMkIV crossbars, easy to be assembled and disassembled, thanks to the quick lock-release system and with safety hooks for extra safety.
- Pair of crossbars and suction cup units for crossbars are available as accessories.
- Equipped with plastic suction cups protections, use and maintenance manual.

SPECIFICATIONS AND VERSIONS

Part No.	Barcode	Box Icon	Description	Weight	Dimensions	Net Weight
432EM04V150	8050532016989	1	EASY-MOVE 150 pair of handling devices with fixed length profiles with 4 "RV175" vacuum (pump) suction cups	10,4 Kg 22.9 lbs	180x37x h 30 cm 71"x14"xh 12"	14,2 Kg 31.3 lbs

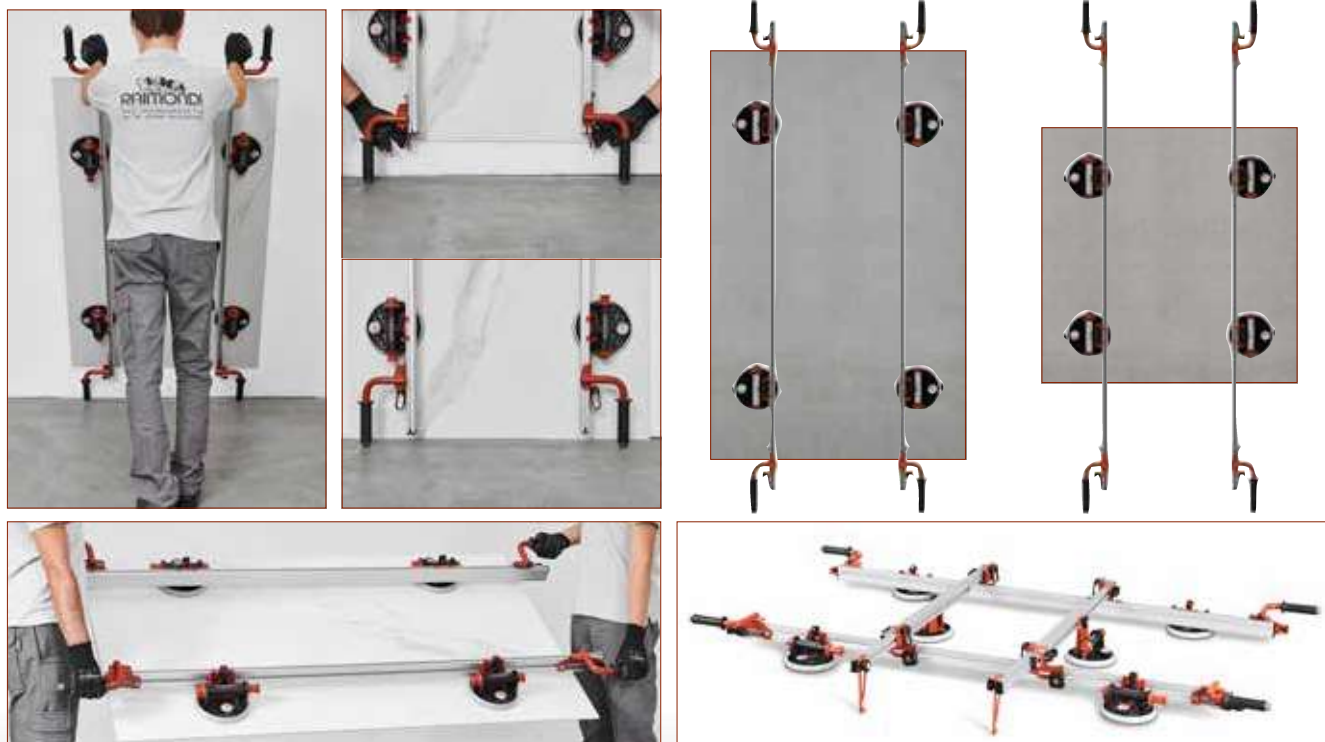

TOOLS FOR LARGE FORMAT TILES



Power-Vacuum kit mounted on EASY-MOVEMkIV with crossbars (Art. 432HAKITR + Art. 432EM04TA).

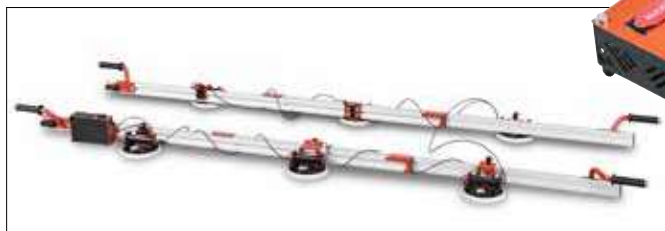

Power-Vacuum kit mounted on EASY-MOVEMkIV without crossbars (Art. 432HAKITR + Art. 432EM04CA).



432HAKITR

PACKAGE



CARTON BOX

- Vacuum circuit device to connect and simultaneously engage up to 8 suction cups designed for EASY-MOVE handling frames (only those equipped with vacuum suction cups; any version).
- Simply by pushing a button, the vacuum level is raised on all suction cups connected to the circuit, saving a significant amount of time compared to manual engagement.
- The kit includes:
 - the main unit with battery and vacuum pump (to be fastened to the frame via the provided strap)
 - vacuum nozzles to be fitted into suction cups by replacing the pistons
 - polyamide pipes
 - protective padded carry bag (provided with both handles and shoulder belt)
 - service kit, user's and maintenance manual;

- Should a suction cup loose its adhesion or a pipe being accidentally damaged, the remaining cups will stay engaged.
- The device is suitable with any version of EASY-MOVE handling frame equipped with any version of Vacuum suction cups. With or without crossbars.
- The device is compact in size and weight (2.7 Kg – 6.4 lbs), it does not affect the handling performances of the EASY-MOVE frame.
- Battery powered (38.5 Wh): long working span and long life.

SPECIFICATIONS AND VERSIONS

Part No.	Barcode	Carton	Description	Use	Battery	Weight	Dimensions	Capacity
432HAKITR	8050532013650	1	Power-Vacuum Kit: vacuum circuit device to connect and simultaneously engage up to 8 vacuum pump suction cups	On all handling frames with VACUUM pump suction cups (up to 8)	38.5 Wh	2,7 Kg 5.9 lbs	45x23x h16 cm 17 2/8" x 9" x h 6 1/8"	3,1 Kg 6.8 lbs



ACCESSORIES AND SPARE PARTS FOR EASY-MOVE ^{MkIV}

MADE IN ITALY



432E004TR



432E004VA

VERTOSE
ANTIMACCHIA
STAIN FREE
SUCTION CUPS



432E004VB

VERTOSE
ANTIMACCHIA
STAIN FREE
SUCTION CUPS

360°
UPGRADE

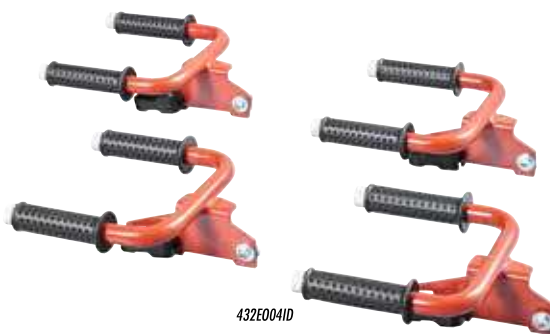

432E004ID



185WR01A



185WR02A

PACKAGE



CARTON BOX

ACCESSORIES AND SPARE PARTS FOR EASY-MOVE ^{MkIV}

Part No.			Description						
432E004TR	8050532010581	1	Pair of crossbars for EASY-MOVE ^{MkIV}	5,4 Kg	11.9 lbs	101x12xh15 cm	40"x5"x6"	6,3 Kg	13.8 lbs
432E004VB	8050532010604	1	Kit of 2 double suction cup for EASY-MOVE ^{MkIV}	2,3 Kg	5 lbs	37x19xh 17 cm	14"x7 1/2"x h 7"	2,5 Kg	5.5 lbs
432E004VA	8050532010598	1	Kit of 2 vacuum suction cups "RV175" for EASY-MOVE ^{MkIV} crossbars	2 Kg	4.4 lbs	37x19xh 17 cm	14"x7 1/2"x h 7"	2,2 Kg	4.8 lbs
432E004ID	8050532010574	1	Kit of 4 double grip handles for EASY-MOVE ^{MkIV} and EASY-MOVE ^{MkIII}	4,5 Kg	9.9 lbs	40x40xh 15 cm	15 3/4" x 15 3/4" x h 6"	5 Kg	11 lbs
185WR01A	8050532011434	1	Stain-free rubber cup + pads	145 gr	5.1 oz	-	-	-	-
185WR02A	8050532011441	1	Vacuum gauge + OR	30 gr	1 oz	-	-	-	-

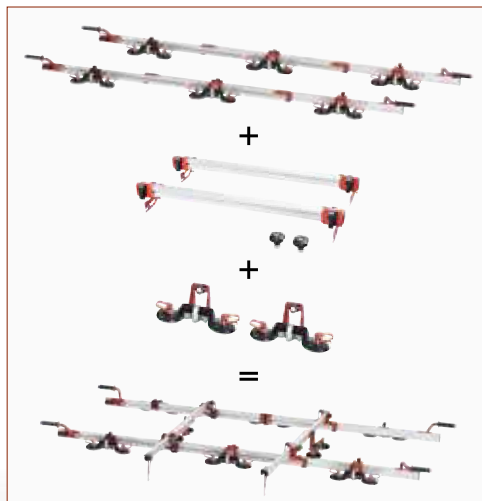
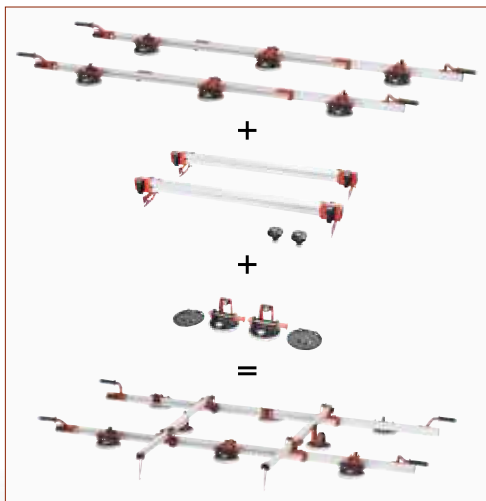

TOOLS FOR LARGE FORMAT TILES



Maintenance kit and protection cup.



PACKAGE



"VACUUM" PUMP SUCTION CUP WITH VACUUM GAUGE

- RV 175: "vacuum" pump suction cup with vacuum gauge designed for handling ceramic tiles and slabs that guarantees perfect grip even on textured tiles. RV 175 is also suitable for lifting any non-porous material such as marble, granite, glass, etc.
- The vacuum gauge allows to constantly monitoring the gripping status of the suction cup, informing the operator when it is necessary to restore the vacuum level.
- The stain-free rubber cup is easily removable from the die-cast aluminum main body and can therefore be replaced if necessary.
- RV 175 is equipped with a carry case, complete with protection cup and maintenance kit.

- The vacuum gauge is protected against impacts and can be easily replaced, if necessary. In the event of accidental breakage, a dedicated screw is included into the maintenance kit, which allows the suction cup to be used without the vacuum gauge.
- High performance vacuum valve, resistant to corrosion.
- Maximum load capacity: 130 Kg (286.6 lbs).
- Safety factor 1.5.
- Ø 175 mm (6 7/8") cup.

SPECIFICATIONS AND VERSIONS

Part No.	Barcode	Quantity	Description	Weight (Kg)	Weight (lbs)	Dimensions (cm)	Dimensions (in)	Volume (Kg)	Volume (lbs)
185WA01VRV	8050532011281	1	RV175 - "Vacuum" pump suction cup with vacuum gauge	1,7 Kg	3.7 lbs	34x30xh 13 cm	13 1/2" x 11" x h 5 1/8"	2,2 Kg	4.8 lbs

REPLACEMENT PARTS

Part No.	Barcode	Quantity	Description	Weight (gr)	Weight (oz)	Dimensions (cm)	Dimensions (in)	Volume (Kg)	Volume (lbs)
185WR01A	8050532011434	1	Suction cup rubber + pads	145 gr	5.1 oz	-	-	-	-
185WR02A	8050532011441	1	Vacuum gauge + OR	30 gr	1 oz	-	-	-	-

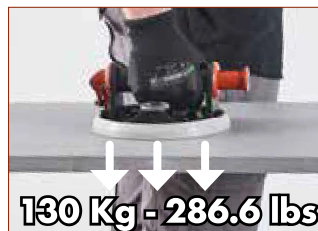

SINGLE, DOUBLE AND TRIPLE SUCTION CUPS

MADE IN ITALY



PACKAGE



MEDUSA - SINGLE PAD SUCTION CUP FOR TILES WITH SMOOTH SURFACE

- Professional suction cup with single pad for handling ceramic tiles and other non-porous materials (i.e.: glass).
- Only suitable for tiles with smooth (untextured) tile surfaces.
- Ergonomic handle to engage/disengage tiles with a single hand.

- Ø 115 mm (4.5") rubber pad with metal insert.
- Maximum load capacity with tile on horizontal position (on smooth and clean surfaces): 24 Kg – 59.2 lbs (safety factor 1.5).
- Supplied packed into a display box with removable lid (holds 10 pieces).

Part No.	Barcode	Box	Description	Weight	Volume	Dimensions	Capacity
185	8024648000354	10	Medusa - single pad suction cup for tiles with smooth surface	340 gr / 12 oz	27x39xh 20 cm	10 5/8"x15 1/8"xh 8"	3,7 Kg / 8.1 lbs

MEDUSA PLUS - SINGLE PAD SUCTION CUP FOR TILES WITH BOTH SMOOTH AND STRUCTURED SURFACE

- Professional suction cup with single pad for handling ceramic tiles and other non-porous materials (i.e.: glass).
- Suitable for tiles with both smooth and textured surfaces thanks to its special triple-lip rubber pad.
- Ergonomic handle to engage/disengage tiles with a single hand.
- Ø 112 mm (4.4") pad made of stain-free gray rubber with metal insert.

- Rubber pad with tab for easy release from the smoothest surfaces.
- Maximum load capacity with tile on horizontal position (on smooth and clean surfaces): 30 Kg – 66.1 lbs (safety factor 1.5).
- Supplied packed into a display box with removable lid (holds 10 pieces).

Part No.	Barcode	Box	Description	Weight	Volume	Dimensions	Capacity
185MEMK3RP	8050532023857	10	Medusa PLUS - single pad suction cup for tiles with both smooth and structured surface	340 gr / 12 oz	27x39xh 20 cm	10 5/8"x15 1/8"xh 8"	3,7 Kg / 8.1 lbs

BIVENTOSA PLUS - DOUBLE PAD SUCTION CUP FOR TILES WITH BOTH SMOOTH AND TEXTURED SURFACE

- Professional suction cup with double pad for handling ceramic tiles and slabs and other non-porous materials (i.e.: glass).
- Suitable for tiles with both smooth and textured surfaces thanks to its special triple-lip rubber pad.
- Sturdy, light and long-lasting die-cast aluminum body.
- Ø 112 mm (4.4") pad made of stain-free gray rubber with metal insert.

- Rubber pad with tab for easy release from the smoothest surface.
- Maximum load capacity with tile on horizontal position (on smooth and clean surfaces): 57 Kg - 125.6 lbs (safety factor 1.5).
- Supplied packed into a display box with removable lid (holds 6 pieces).

Part No.	Barcode	Box	Description	Weight	Volume	Dimensions	Capacity
185BIMK3RP	8050532023840	6	Biventosa PLUS - double pad suction cup for tiles with both smooth and textured surface	815 gr / 28.7 oz	27x39xh 20 cm	10 5/8"x15 1/8"xh 8"	5,2 Kg / 11.5 lbs

TRIVENTOSA PLUS - TRIPLE PAD SUCTION CUP FOR TILES WITH BOTH SMOOTH AND STRUCTURED SURFACE

- Professional suction cup with triple pad for handling ceramic tiles and slabs and other non-porous materials (i.e.: glass).
- Suitable for tiles with both smooth and textured surfaces thanks to its special triple-lip rubber pad.
- Sturdy, light and long-lasting die-cast aluminum body.
- Ø 112 mm (4.4") pad made of stain-free gray rubber with metal insert.

- Rubber pad with tab for easy release from the smoothest surfaces.
- Maximum load capacity with tile on horizontal position (on smooth and clean surfaces): 74 Kg – 163.1 lbs (safety factor 1.5).
- Supplied packed into a display box with removable lid (holds 4 pieces).

Part No.	Barcode	Box	Description	Weight	Volume	Dimensions	Capacity
185TRMK3RP	8050532023949	4	Triventosa PLUS - triple pad suction cup for tiles with both smooth and structured surface	1,15 Kg / 2.5 lbs	27x39xh 20 cm	10 5/8"x15 1/8"xh 8"	4,9 Kg / 10.8 lbs



TOOLS FOR LARGE FORMAT TILES

ONLY-ONE - DEVICE TO ASSIST INSTALLATION OF LARGE FORMAT TILES/SLABS

MADE IN ITALY



432KR02A

PACKAGE



ONLY-ONE mounted on EASY-MOVEMkIV (Art 432KR02A + Art. 432EM04CA).

- Device to assist installation of large format tiles/slabs.
- It allows a single operator to collect a tile sized up to 150x150 cm (59"x59") from the floor and transport it to the installation area, back butter it, and lay it down next to the tile previously installed.
- On tile bigger than 150x150 cm (59"x59"), it provides excellent support for handling and installation process.
- Suitable for tile thickness from 3 mm up to 20 mm (1/8" – 3/4");
- Suitable with EASY-MOVE handling frames ^{MkIII} and ^{MkIV} versions.
- ONLY-ONE includes:
 - Cart with 4 swiveling wheels which can be repositioned according to the tile size.
 - Two ergonomic handles (to be fitted to the profiles of EASY-MOVE 150 and/or EASY-MOVE version ^{MkIV} and ^{MkIII}) equipped with a quick coupling system to the cart and anti-slip rubber pads (to safely perform back buttering).

SPECIFICATIONS AND VERSIONS

Part No.			Description	Use			
432KR02A	8050532018068	1	ONLY-ONE: device to assist installation of large format tiles/slabs	On Easy-Move ^{MkIII} and Easy-Move ^{MkIV} (with double and vacuum suction cups, with and without crossbars)	8,9 Kg 19.6 lbs	117x20x h20 cm 46"x8"xh 8"	11,3 Kg 24.9 lbs



CAM ^{MkIII} - CART FOR LARGE FORMAT TILES AND HANDLING DEVICES TRANSPORTATION AND STORAGE

MADE IN ITALY



169CEL UN



CAM ^{MkIII} disassembled.



CAM ^{MkIII} in transport configuration.

PACKAGE



CARTON BOX

- Cart designed for the transport and handling of large format tiles (for instance 3200x1600 mm - 10.5'x5.2').
- Lightweight (20,4 Kg – 44.9 lbs), it can be quickly disassembled for maximum ease of use and to minimize its volume for ease of transportation.
- It allows to easily and safely spread adhesive in the back of the tile ("back-buttering"). For this purpose, it comes with two height-adjustable hooks for holding the handling devices (i.e.: EASY-MOVE) with the slab fasten on them.
- When the handling devices / frames are on the CAM MkIII, the suction cups remain fully accessible. If needed, this allow to easily restore the vacuum level. This feature is particularly relevant when installing textured large format tiles.
- One side of the cart can be used as storage for the transport of one or more slabs.
- Wooden shelves on both sides of the cart provide safe support for large format tiles.
- On the storage side there are 2 height-adjustable rubber supports and plastic protections to prevent any accidental damage to the slabs.
- Height-adjustable safety hooks (which can be adapted to the dimension of the slab) to prevent slabs to fall.
- Two of the four pivoting wheels are provided with brakes so to prevent the cart to accidentally move.
- Maximum load: 250 Kg (551 lbs).

SPECIFICATIONS AND VERSIONS

Part No.			Description			
169CEL UN	8050532016521	1	CAM ^{MkIII} - Cart for the transport and handling of large format tiles and for the application of the adhesive in the back of the tile ("back-buttering")	20,4 Kg 45 lbs	160x60x h23 cm 63"x23 5/8"xh 9 1/16"	25,8 Kg 56.9 lbs



TOOLS FOR LARGE FORMAT TILES



432ZC6R

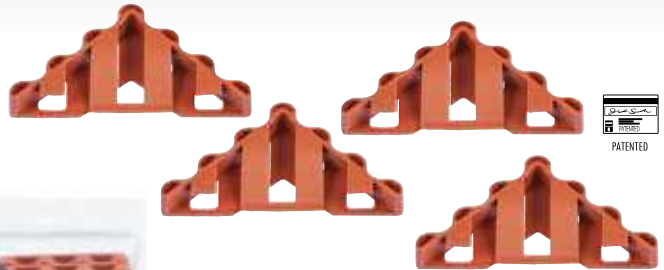

BLISTER

432SSBRAI



TYRREL

- Compact cart for handling and transporting tiles and slabs.
- Maximum ease of transport with minimum size.
- Capable to travel on uneven surfaces (for instance even on up to 2 cm – 3/4" lippage).
- Tiles/slabs rest onto a wooden support to prevent accidental damage.
- To grant maximum stability and maneuverability, it is equipped with 6 wheels, 4 of which are swiveling.

- Handles carved into frame for convenient transportation.
- Maximum load capacity: 210 Kg (463 lbs).
- Can be used in combination with handling frames (i.e.: EASY-MOVE).

SPECIFICATIONS AND VERSIONS

Part No.	Barcode	Quantity	Description	Weight	Dimensions	Volume
432ZC6R	8050532020597	1	TYRREL - Cart for transporting tiles and slabs	8,6 Kg 18.9 lbs	72x27x h 23 cm 28"x10.5"x h 9 1/8"	9,2 Kg 20.3 lbs

CORNER PROTECTOR

- Corner protectors studied mainly for large format tiles but suitable for all kind of tiles. Even for glass or other materials.
- Suitable for tiles and slabs with 3-12 mm thickness; so one product covers all large format tiles thicknesses.
- They are very important when handling large format tiles to avoid potential damages to the most delicate parts of the slab (the corners indeed - and the edges).

- Inserting the product on the corner is easy and fast.
- Once inserted, it firmly remains into position, thanks to a clip that maintains its support on the corner.
- Sold into a 4 pieces transparent blister.
- Made of sturdy plastic.

SPECIFICATIONS AND VERSIONS

Part No.	Barcode	Quantity	Description	Thickness	Width	Weight	Volume	Dimensions	Volume
432SSBRAI	8050532008687	8	Corner protector (4 pcs)	3 - 12 mm	1/8" - 1/2"	150 gr 5.3 oz	32x32xh 8 cm	12 1/2" x 12 1/2" x h 3 1/8"	1,2 Kg 2.6 lbs

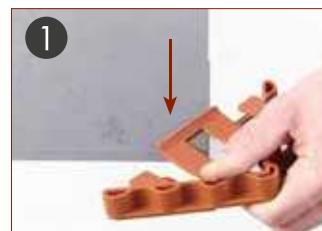
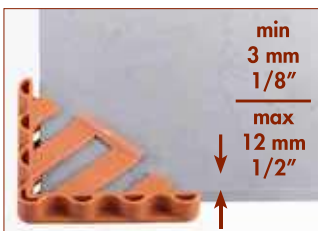



321BATPRR



142G



Supplied with bag.

2-in-1 products.

PACKAGE



- Professional cordless vibrator designed to vibrate large format tiles in order to expel the air from underneath the slab (avoiding air pockets), so to obtain the perfect adhesive coverage;
- Extremely effective also for the perfect bonding of uncoupling and waterproofing membrane sheaths;
- Battery powered: no more cords getting in the way;
- The battery provides abundant autonomy: within 150 and 200 m² (1,600 - 2,100 sq. ft.) vibrated surface on a single charge. The battery has a very long life: more than 100.000 m² (1 million sq. ft.) before the performance (of the battery) starts to decrease;
- 21x41 cm (8 1/4"x 16 1/8") vibrating area, ideal for vibrating large format slabs with maximum speed and effectiveness. The vibrating area can be quickly reduced to 15x15 cm (6"x6") to vibrate smaller surfaces and / or small tiles like steps, planks, columns;
- Ideal to be used both on wall and floor thanks to its extremely low weight: 5,8 Kg (12.8 lbs)

- with 24x41 cm (8 1/4"x 16 1/8") vibrating plate; 3,1 Kg (6.8 lbs) with 15x15 cm (6"x6") vibrating plate;
- PVC vibrating area (plates) provide low friction onto slab surface, ensuring a low user fatigue and, thanks to its rigidity, they transfer to the slab/sheaths the entire vibrating force;
- The high frequency vibrations guarantee maximum efficiency by minimizing mechanical stress to the tile/slab, even in critical situations (for instance a low thickness slab with large cut-openings, C shaped cutouts or multiple round holes);
- 3 handles: two externals for two-hands use and one central for one-hand use;
- High vibration frequency (motor Rpm: 3.500);
- Motor: 15V direct current, battery power 38.5 Wh;
- Supplied with a protective padded bag (provided with both handles and shoulder belt) ideal for both transport and storage.

SPECIFICATIONS AND VERSIONS

Part No.	Barcode	Box	Description	Motor	Battery	Weight	Dimensions	Net Weight
321BATPRR	8050532013339	1	e-FOX professional tiles/slabs vibrator, battery powered, supplied with a 21x41 cm (8 1/4"x 16 1/8") vibrating plate, battery charger, bag	15V	38.5 Wh	5,8 Kg 12.8 lbs	45x23x h16 cm 17 2/8"x9"xh 6 1/8"	6,2 Kg 13.7 lbs

RUBBER ANTI-BOUNCING TILE BEATER

- To improve adhesive bounding and to expel air from underneath the slabs/tiles.
- Rubber bottom to prevent tiles/slabs damages.

- Sturdy galvanized steel structure.
- The off-set handle increases effectiveness.

Part No.	Barcode	Box	Description	Dimensions	Weight	Net Weight	Dimensions	Net Weight
142G	8024648078582	6	Rubber tile beater	145x350 mm 5 3/4"x13 3/4"	1,5 Kg 3.3 lbs	40x40xh 15 cm 5 3/4"x12 5/8"xh 4 3/4"	9,4 Kg 20.7 lbs	



TOOLS FOR LARGE FORMAT TILES



CLOSER PLUS - DEVICE TO ALIGN SLABS WITH BOTH SMOOTH AND STRUCTURED FINISH

- To align large format tiles during installation by simply turning a knob.
- Suitable for tiles either with textured or smooth surface finish.
- Equipped with 2 Triple suction cup PLUS (total of 6 suction cups Ø 112 mm – 4.4”) suitable for both tiles / slabs with structured and smooth surface finish.

- Stain-free grey rubber pads with tab to facilitate disengagement from smooth surfaces.

SPECIFICATIONS AND VERSIONS

Part No.	Barcode	Description	Weight	Dimensions	Volume
185DALMK2	8050532024878	2 CLOSER PLUS - Device to align tiles/slabs with triple suction cups (Triventosa PLUS) with stain-free-rubber	4 Kg 8.8 lbs	58x30xh 25 cm	23”x12”xh 10”

LEVTOP FLAT - DEVICE FOR INSTALLATION OF COUNTERTOPS AND FURNITURE ELEMENTS

- To level and align kitchen / bathroom countertops (or other furnishing elements) during the installation phase.
- Suitable for flat installations.
- Equipped with a leveling unit.
- Thanks to the vacuum device, the grip can be restored without removing the suction cup from the slab to grant consistent support during the maturation of the bonding agent
- The vertical leveling is achieved via 2 height adjustable feet with knobs which are meant to be

- positioned on the 2 countertop sections (slabs): the perfect flatness of the 2 countertop sections (slabs) is achieved thanks to the vertical adjustment of the 2 feet.
- The horizontal alignment of the 2 countertop sections is achieved via a knob which controls with high accuracy the clearance between the 2 suction cups.
- Equipped with 2 vacuum suction cups RV175 (Ø 175 mm – 6 7/8”) with stain-free rubber pad, ideal for tiles either with textured or smooth surface finish.
- Suction cups equipped with vacuum gauge.

SPECIFICATIONS AND VERSIONS

Part No.	Barcode	Description	Weight	Dimensions	Volume
185ARLIVAF	8050532024212	1 LEVTOP FLAT - Device for installation of countertops and furniture elements with RV175 vacuum suction cups with stain-free-rubber	2,9 Kg 6.4 lbs	58x30xh 25 cm	23”x12”xh 10”

LEVTOP PLUS - DEVICE FOR INSTALLATION OF COUNTERTOPS AND FURNITURE ELEMENTS WITH VARIABLE ANGLE

- To align, level and move sideways kitchen / bathroom countertops (or other furnishing elements) during the installation phase.
- Suitable for both flat and corner installations.
- Equipped with two leveling units
- The vertical leveling is achieved via 4 height adjustable feet with knobs which are meant to be positioned on the 2 countertop sections (slabs): the perfect flatness of the 2 countertop sections (slabs) is achieved thanks to the vertical adjustment of the 4 feet.
- The horizontal alignment of the 2 countertop sections is achieved via a knob which controls with high accuracy the clearance between the 2 suction cups.

- By acting onto knob, the 2 countertop sections (slabs) can be moved to achieve a perfect alignment of the outer edges of the countertop .
- All adjustments can be achieved either on slabs laid horizontally or with an angle (to be equal, larger or smaller than 90 ° - action range 192 °)
- Equipped with 2 vacuum suction cups RV175 (Ø 175 mm - 6 7/8”) with stain-free rubber pad, ideal for tiles either with textured or smooth surface finish.
- Suction cups equipped with vacuum gauge.
- Thanks to the vacuum device, the grip can be restored without removing the suction cup from the slab to grant a consistent support during the maturation of the bonding agent.

SPECIFICATIONS AND VERSIONS

Part No.	Barcode	Description	Weight	Dimensions	Volume
185ARLIVAV	8050532024229	1 LEVTOP PLUS - Device for installation of countertops and furniture elements with variable angle with RV175 vacuum suction cups with stain-free-rubber	3,5 Kg 7.7 lbs	45x23xh 16 cm	17 2/8”x9”xh 6 1/8”

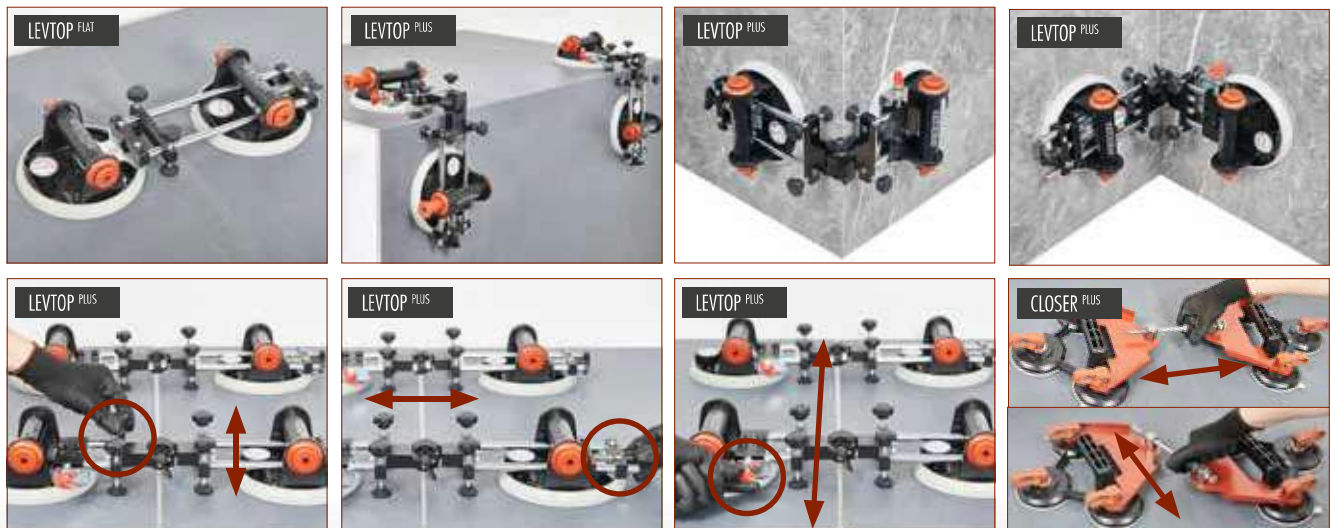

OTHER TOOLS FOR LARGE FORMAT TILES AND TOOLS BAG

MADE IN ITALY



PACKAGE



DIAMOND PADS

- To finish the edges of tiles / slabs after cutting.
- Available grains 60 and 200.

Part No.	Barcode	Box	Description	Grain	Size	Weight	Weight
227D060	8024648077578	5	Diamond pad 55x90 mm grain 60	60	55x90 mm	2 1/8"x3 1/2"	10 gr 0.35 oz
227D200	8024648077585	5	Diamond pad 55x90 mm grain 200	200			55 gr 1.9 oz

GRINDING DISCS WITH DIAMOND LAMELLAS

- Lamellar grinding discs for shaping porcelain tiles/slabs edges
- Three grits are available: 60, 120 and 200.
- Use: both dry and with water.

Part No.	Barcode	Box	Description	Water	Sun	Weight	Weight
274FDLAM060	8050532012417	5	Lamellar disc grain 60	•	•	90 gr 3.1 oz	-
274FDLAM120	8050532018556	5	Lamellar disc grain 120	•	•		-
274FDLAM200	8050532012950	5	Lamellar disc grain 200	•	•		-

DIAMOND PADS FOR EDGE AND SIDE FINISHING / POLISHING

- Use on angle grinder RPM: min 1.800 / MAX 4.000

Part No.	Barcode	Box	Description	Water	Sun	Material	Grain	Weight	Weight
274FDGP50	8050532006713	1	Kit of 7 diamond pads	-	•	for porcelain	Ø 100	80 gr 2.8 oz	
274FD100G0050	8024648097293	5	Diamond pad grain 50	-	•	-	Ø 100	gr.50 50 gr 1.8 oz	
274FD100G0100	8024648081933	5	Diamond pad grain 100	-	•	-	Ø 100	gr.100 50 gr 1.8 oz	
274FD100G0200	8024648081940	5	Diamond pad grain 200	-	•	-	Ø 100	gr.200 50 gr 1.8 oz	
274FD100G0400	8024648081957	5	Diamond pad grain 400	-	•	-	Ø 100	gr.400 50 gr 1.8 oz	
274FD100G0800	8024648081964	5	Diamond pad grain 800	-	•	-	Ø 100	gr.800 50 gr 1.8 oz	
274FD100G1500	8024648081971	5	Diamond pad grain 1500	-	•	-	Ø 100	gr.1500 50 gr 1.8 oz	
274FD100G3000	8024648081988	5	Diamond pad grain 3000	-	•	-	Ø 100	gr.3000 50 gr 1.8 oz	
274CV100G80	8024648015648	5	Zirconium abrasive disc with Velcro attachment grain 80	-	•	-	Ø 115	gr.80 50 gr 1.8 oz	
274FD100A	8024648081506	1	Pad with velcro Ø 100 mm - 14MA attachment	-	•	-	Ø 100	- 60 gr 2.1 oz	

TOOL BAG

- Protective padded bag ideal for both transporting and storing the machine (i.e.: E-Fox) or other tools/accessories.
- Provided with both handles and shoulder belt.
- One internal pocket.
- Equipped with a zip along the opening on the top of the bag.

Part No.	Barcode	Box	Description	Weight	Weight
321TS01A	8050532019577	1	Tool bag	50 gr 1.8 oz	-



TOOLS FOR LARGE FORMAT TILES



MADE IN ITALY



433KOMOH
Angle grinder not included

ANTIACCHIA
STAIN FREE
SUCTION CUP

179FLEX012SE
179FLEX010SE
179FLEX006SE

179FLEX45SE

179FLEX45SERF

PACKAGE
CARTON BOX

- MOTOKOMPASS is a device designed to create rounded or with rounded corner furnishing elements.
- Possible diameters to perform: minimum 30 cm, maximum 100 cm.
- It is possible to perform both half/bullnose and 45° miter (jolly) profiles.
- Half/bullnose profiles can be performed on slabs and tiles with a thickness from 5 to 12 mm. Available radius: 6 mm, 10 mm, 12 mm.
- 45° miter (jolly) profiles can be performed on slabs and tiles with a thickness from 3 to 12 mm.
- For finishing/polishing the shaped edges, it is recommended to use an angle grinder freehand (max 1400 rpm) with diamond pads.
- It can be either used dry (with a dust extractor) or with water (with kit for wet cut art. 433PWW A).
- Suitable with almost all angle grinders with power between 600-1100W.
- Available for grinders with M14 arbor attachment (Art. 433KOMOHR) and for angle grinders with 5/8" - 11 arbor attachment (Art. 433KOMOHUS).
- Equipped with: "RV 175" vacuum pump suction cup with vacuum gauge for use on textured surfaces (special references on the suction cup are available in order to correctly position the suction cup in relation to the work to be performed), scoring device with diamond wheel Ø 16mm, housing unit for angle grinder for shaping edges, cutting-off plier for snap after the scoring cut, use and maintenance manual.
- Angle grinder and diamond tools are not included: they have to be purchased separately.

SPECIFICATIONS AND VERSIONS

Part No.	Box	Barcode	Description	Arbor	Wheel	Grinder	Thickness	Radius	Weight	Dimensions	Capacity
433KOMOHR	1	8050532008700	MOTOKOMPASS - Device for circular shaping. Without angle grinder. Without wheel. With cutting-off plier 3-6 mm.	M14	-	-	12 mm 0.47"	12 mm 0.47"	5,4 Kg 11.9 lbs	80x33x h 21 cm 31 1/2"x13"xh 8"	6,5 Kg 14.3 lbs
433KOMOHUS	1	8050532011434		5/8"-11	-	-					

SPECIFICATIONS AND VERSIONS

Part No.	Box	Barcode	Description	Profile	Ø	Radius	Water	Dust
179FLEX006SE	1	8024648094834	Shaping wheel for 1/2 bullnose	[Diagram of 1/2 bullnose profile]	120 mm 4 3/4"	6 mm 1/4"	•	•
179FLEX010SE	1	8024648087171	Shaping wheel for 1/2 bullnose		120 mm 4 3/4"	10 mm 3/8"	•	•
179FLEX012SE	1	8050532010970	Shaping wheel for 1/2 bullnose		120 mm 4 3/4"	12 mm 1/2"	•	•
179FLEX45SE	1	8050532010987	Shaping wheel for 45° profile (jolly)	[Diagram of 45° miter profile]	120 mm 4 3/4"	-	•	•
179FLEX45SERF	1	8050532011267	Finishing wheel for 45° profile (jolly)		120 mm 4 3/4"	-	•	•

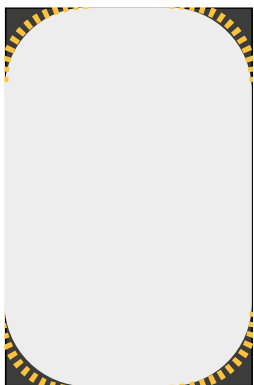

STARTING SLAB
MOTOKOMPASS
FINAL SLAB

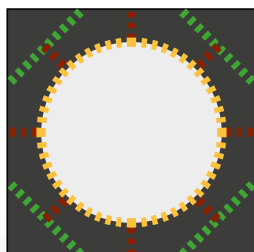

STARTING SLAB
MOTOKOMPASS
CUTTING GUIDE
ANGLE GRINDER
FINAL SLAB



KOMPASS - DEVICE TO PERFORM CIRCULAR CUTS

MADE IN ITALY



ANTIRIFLESSO
ANTIMACCHIA
STAIN FREE
SECTION 0075

KOMPASS scribing

433KOMP 50

slicing via angle grinder

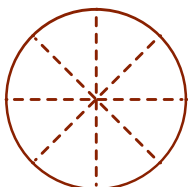

PACKAGE



CARTON BOX

• KOMPASS - DEVICE TO PERFORM CIRCULAR CUTS

- Device to perform large diameter circular cuts on large format tiles using the score and snap system.
- It is possible to perform centered, and off centered holes, in relation to the position of the suction cup which holds the KOMPASS to the slab.
- Centered holds dimension: min. Ø 22 cm (8 5/8"), max. Ø 100 cm (39 3/8").
- Off-centered hole dimension: min. Ø 32 cm (12 5/8"), max. Ø 100 cm (39 3/8").
- Diamond scoring wheel Ø 16 mm with pin and bearings.
- Metric/imperial ruler with pointer showing hole diameter.
- Light and easy to transport.
- To complete the processing of the hole is almost always necessary to perform slicing with an angle grinder and removing the cloves afterward.
- It is possible to perform a full circular hole, a semicircular hole, and 1/4 of circle, rounding the corner of the slab.

SPECIFICATIONS AND VERSIONS

Part No.	Barcode	Description	CENTERED HOLES Ø DIMENSION	OFF-CENTERED HOLES Ø DIMENSION	Weight	Dimensions
433KOMP 50	8050532000742	1 KOMPASS - device to perform circular cuts	22 cm - 100 cm 8 5/8" - 39 3/8"	32 cm - 100 cm 12 5/8" - 39 3/8"	1,2 Kg 2.6 lbs	15x15xh 69 cm 6"x6"xh 27"

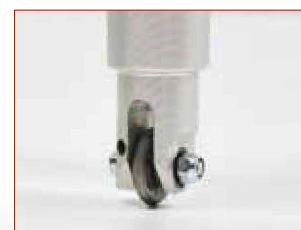
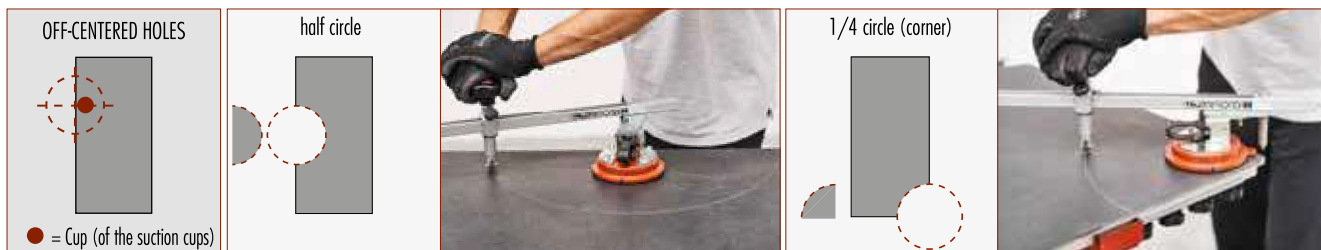

TOOLS FOR LARGE FORMAT TILES



171TG RAI

TIP-TOP. FACE-UP MITER-CLAMPING-DEVICE FOR STAIRS AND COUNTERTOPS OF ANY LENGTH

- Face-up miter clamping devices designed to work with fully visibility of the corner on tiles and stones of any length.
- It allows the user to see the corner with no need to bend.
- Independent double micrometric adjustments (vertical - up and down / horizontal - back and forward) allows to easily create the perfect corner.
- No tile length limits make it perfect for large format porcelain tiles as well.
- As a general guideline we recommend to use a pair (1 kit) on tiles or stones up to 200 cm (6.6') length. For longer tiles just add additional units. Slider adjustment to accommodate laminated edges from 30 to 300 mm (1 3/16" – 12")
- Steps/top dimensions (performances):
 maximum tile length: ∞ (infinite / no limit of length);
 riser: maximum 300 mm (12"); minimum 30 mm (1 3/16").
 maximum tile width: ∞ (infinite / no width limit);

- Suitable also for corner gluing (3 tiles). At least two kits (4 devices) are necessary to perform this particular operation.
- The 3 ballasts weighing a total of 1.2 kg (2.6 lbs) which equip each device contribute to create the perfect weights distribution to keep the tiles in position.
- The 2 stain-free rubber suction cups (Ø 88 mm; 3.5") which equip each device help keeping them in place while doing up & down /back & forward micro-adjustments.
- Black reference bands make it easy and fast to place the devices on the top of the tiles in the right position.
- TIP-TOP is designed to work on the top of the tiles. Tiles must be positioned on a stable, sturdy and big-enough table. We recommend to use one or more BM180^{PLUS} or BM180^{MAX} tables (worktop dimensions up-to 360x150 cm and even more if needed).
- Each TIP-TOP kit consists of two devices / units.
- TIP-TOP is extremely compact and light (6.2 kg / 13.6 lbs per pair / kit) for ease of storage and transport.

SPECIFICATIONS AND VERSIONS

Part No.			Description			
171TG RAI	8050532005686	1	TIP-TOP. Pair of face-up miter-clamping-devices for stairs and countertops of any length	6,2 Kg / 13,7 lbs	50x50xh 27 cm / 20"x20"xh 10 5/8"	9 Kg / 19,8 lbs

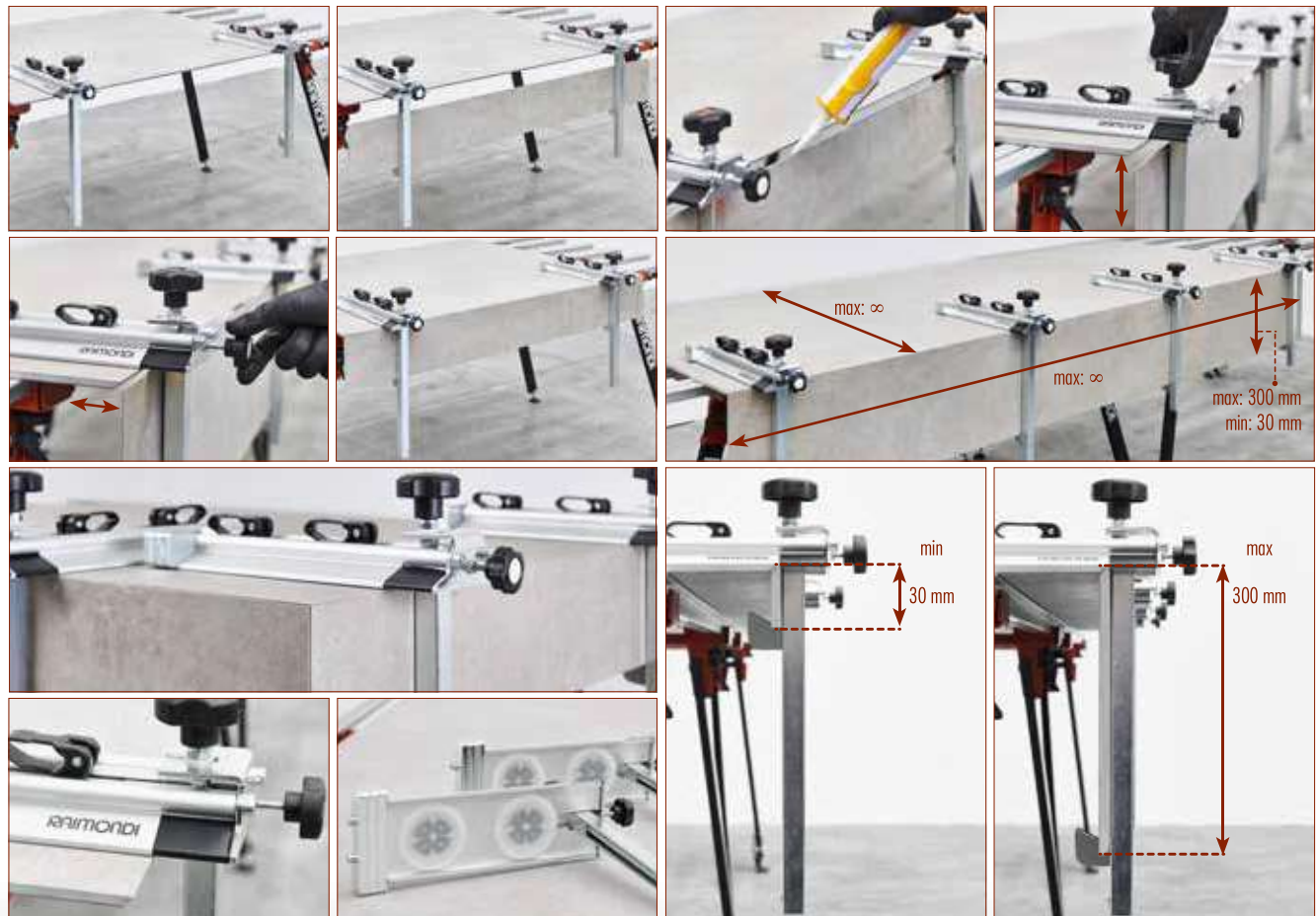

TOOLS FOR LARGE FORMAT TILES

90° GLUING KIT (FOR STEPS AND COUNTERTOP)

MADE IN ITALY

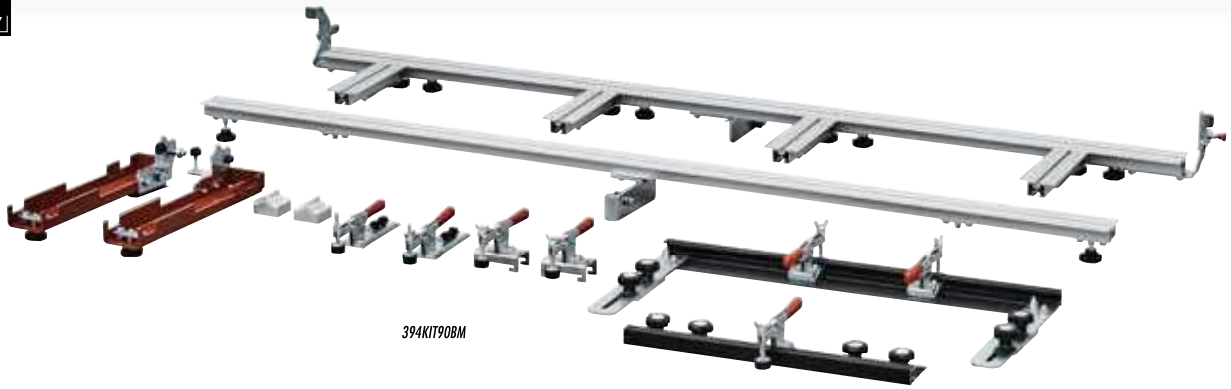

394KIT90BM



* The product does not include BM180^{Mod} modular bench

90° GLUING KIT (FOR STEPS AND COUNTERTOP)

- Miter joining fixture designed to be quickly installed on bench BM180^{MkII} (as well as on previous version) to bond steps, countertops and swimming pool copings.
- The product includes clamps and a pivot mechanism to joint tiles at 90° after miter cut has been performed on them.
- The product includes a pair of aluminum spacers to easily set the proper clearance between the tile pieces to be bonded together.
- The product has been designed to perform up to 2 joints on the same tile and so achieving a "U" shaped steps or counter top.
- Max achievable steps/counter top dimensions:
overall length: 150cm;

- overall height: 20cm;
- overall depth: ∞
- Bench BM180^{MkII} is not included.
- Each Bench BM180^{MkII} can be equipped with up to 2 Miter joining fixture (90° gluing kits).
- Tiles are held in place with removable clamps, easy to be positioned and adjusted.
- The product includes positioning squares for the tile pieces.
- Allows an easy positioning of the tile pieces, is quick to be operated, very sturdy.
- Can be adjusted at any time to keep its accuracy.

Part No.			Description	BM180 MkII	BM180 PLUS			
394KIT90BM	8024648099273	1	90° gluing kit to create steps counter top	•	—	25 Kg 55.1 lbs	213x46xh 15 cm 84"x18"xh 6"	30 Kg 66.1 lbs

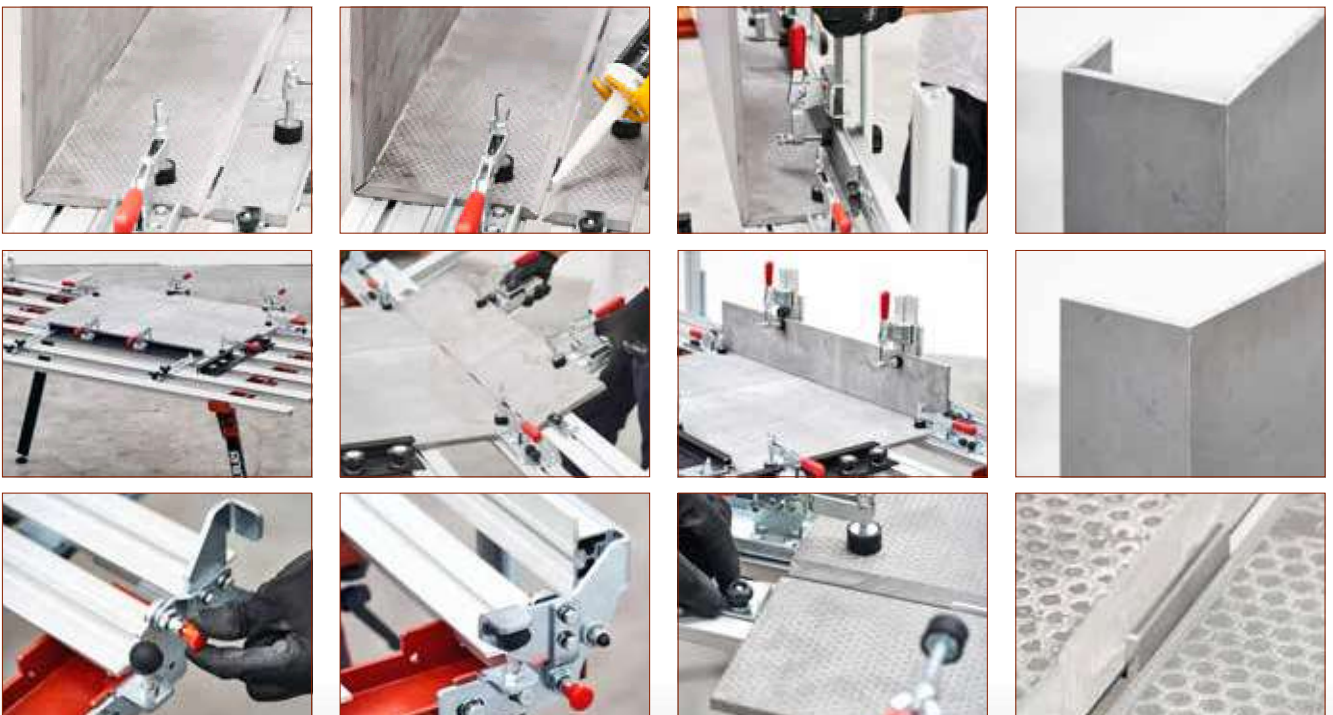

TOOLS FOR LARGE FORMAT TILES