

BRIDGE AND JOB SITE SAW MACHINES



OVERVIEW

WET SAW – CUTTING SPECIFICATIONS GRAPHS A2

BRIDGE WET SAWS

EXPLOIT 70	A4
EXPLOIT 90	A5
EXPLOIT 120	A6
BOLT 90	A7
BOLT 120	A8
BOLT 150	A9
MISTRAL 90	A10
MISTRAL 120	A11
MISTRAL 150	A12
PIKUS 85 ADV	A13
PIKUS 105 ADV	A14
PIKUS 130 ADV	A15
SMS 100	A16
SMS 125	A17
SMS 150	A18
SMS 220	A19
ZOE 85 ADV	A20
ZOE 105 ADV	A21
ZOE 130 ADV	A22
ZOE 150 ADV	A23
LAB 270	A24
LAB 330	A25
LAB 400	A26

TROLLEY WET SAWS

SA80	A27
SA09	A28
SHERPA	A29

ACCESSORIES FOR BRIDGE WET SAWS

TILE HOLDERS, FLANGES, LASERS, DRESSING STONES	A30
SIDE TABLE WITH ROLLERS, SQUARES, WHEELS	A31
SIDE BENCHES AND DIGITAL DISPLAY KITS	A32
MANUAL FEED KIT WITH WHEEL	A33

ACCESSORIES FOR TROLLEY WET SAWS

SQUARES, LASER, DRESSING STONES, HANDLES	A34
--	-----

26 models that vary in performances, technology, size and preferential intended use. This is our wide range of bridge and trolley saw machines.

From the more polyvalent, suitable to cut virtually any material, to the more compact ones studied mainly for cutting porcelain tiles, until the bridge saw designed for perfect cutting of slabs up to 400 cm (13.1'). A vast products portfolio (supported by a wide offer of accessories) from which to choose the model that best fits the needs of every single professional. All characterized by the highest degree of quality, effectiveness and efficiency.

To identify the most suitable model, see also the machines cutting specification graphs on page A2 and A3.

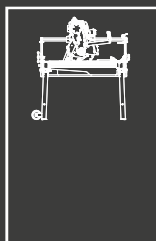

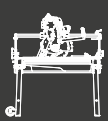

WET SAWS - CUTTING SPECIFICATIONS GRAPHS

MAX LENGTH OF CUT

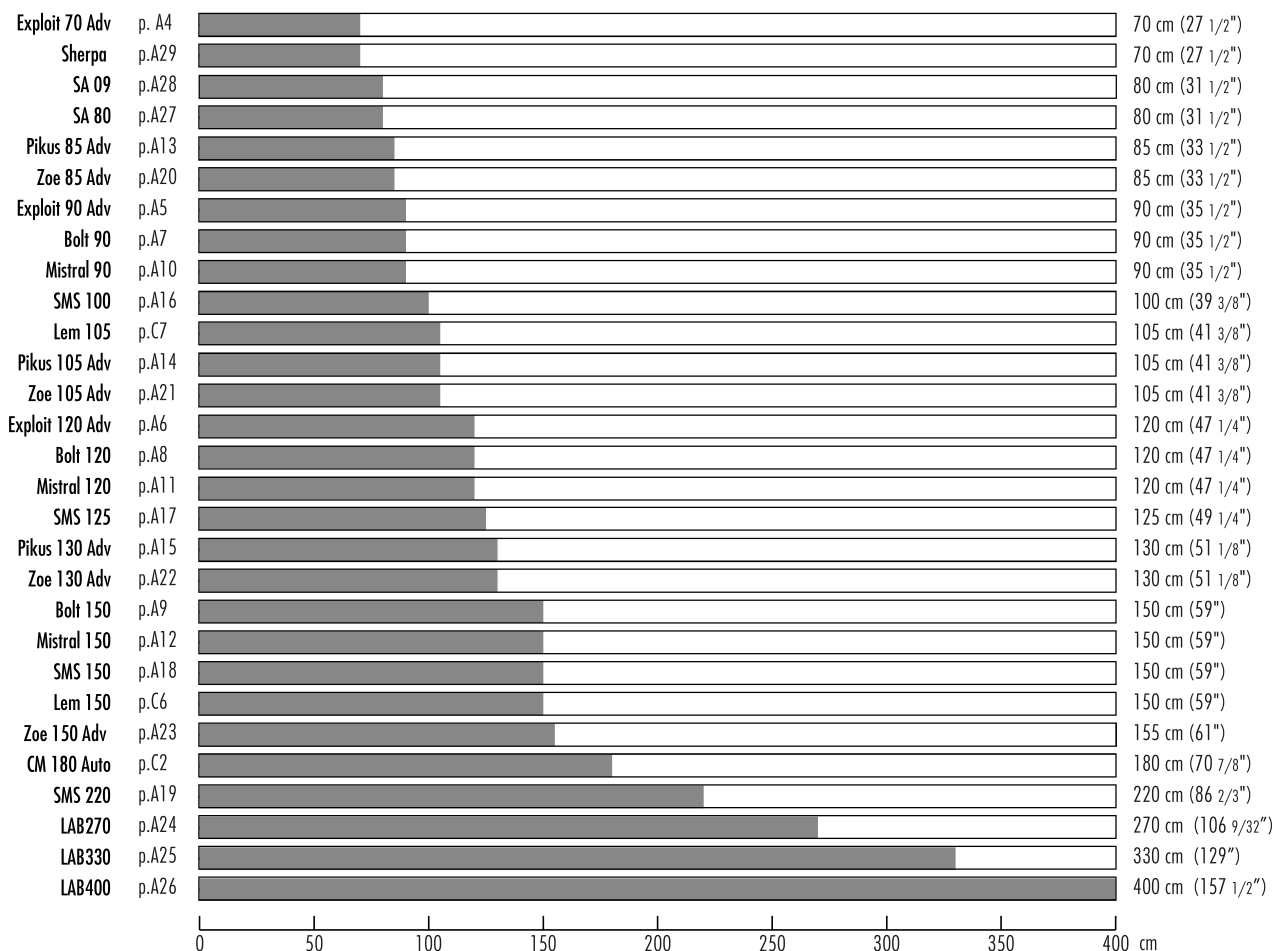

MAX DIAGONAL CUT (TILE SIZE)

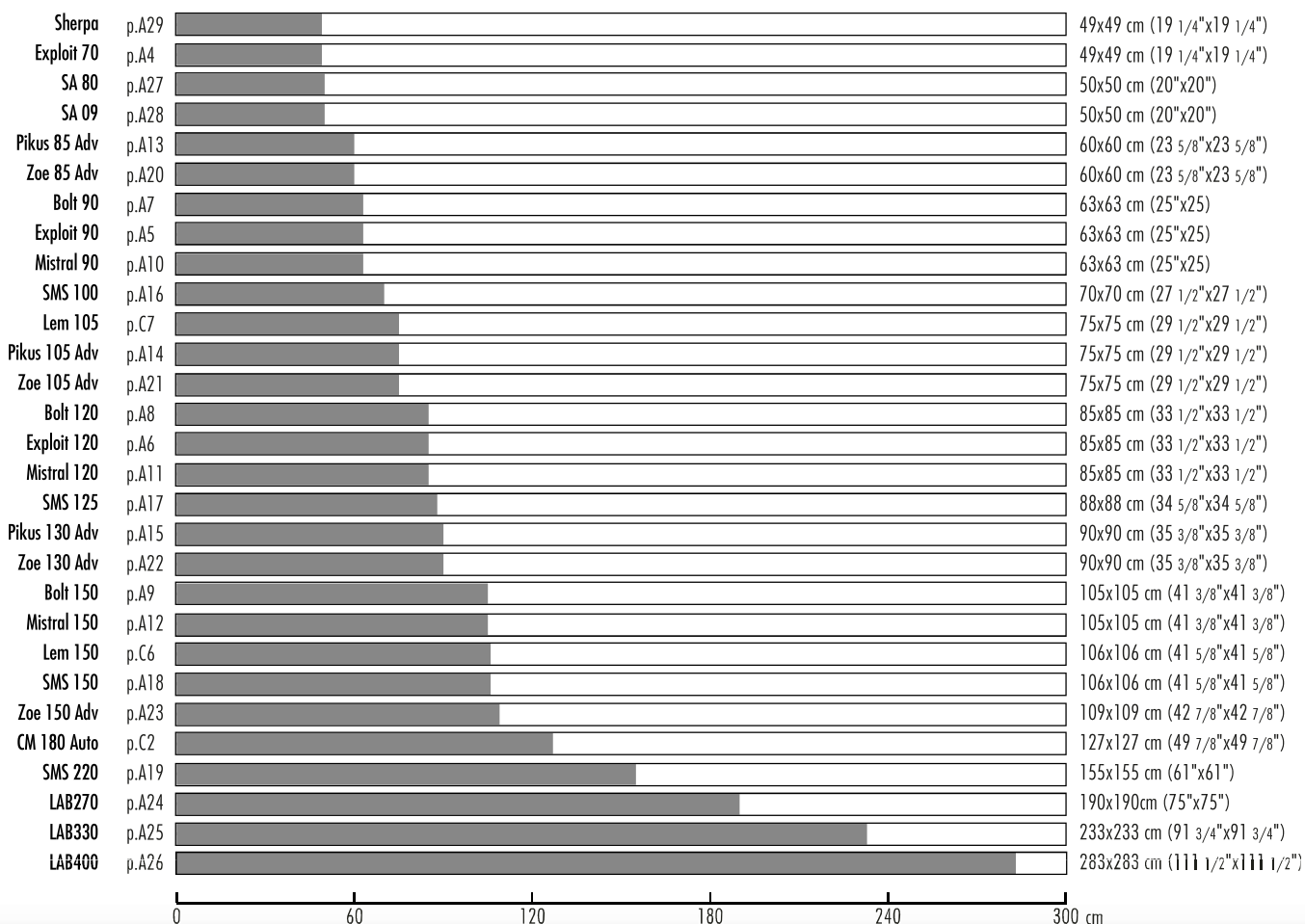



SEGATRICI CON MOTORE O CARRELLO SCORREVOLI

MAX THICKNESS OF CUT (SINGLE PASS)

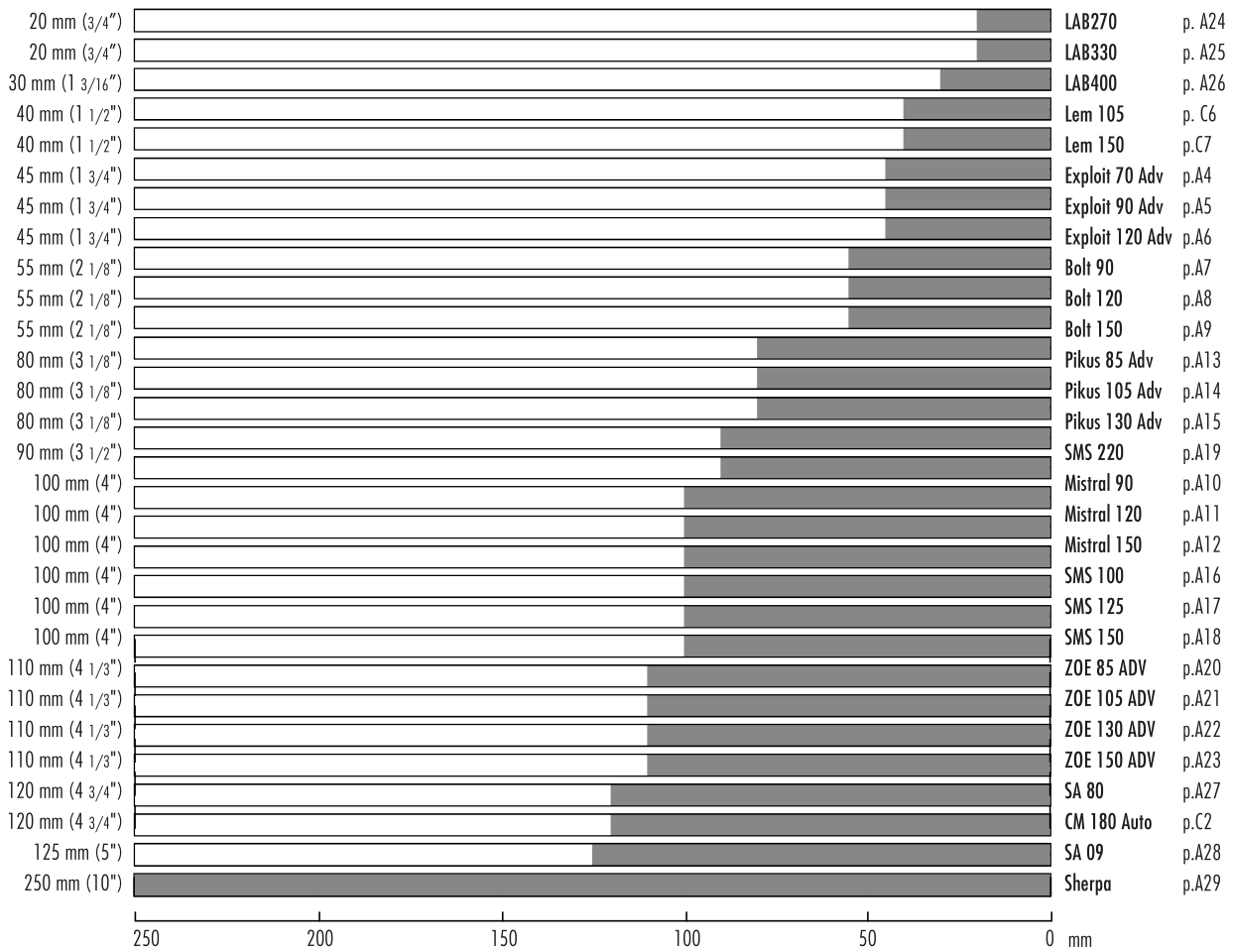

MAX THICKNESS OF CUT (DOUBLE PASS)

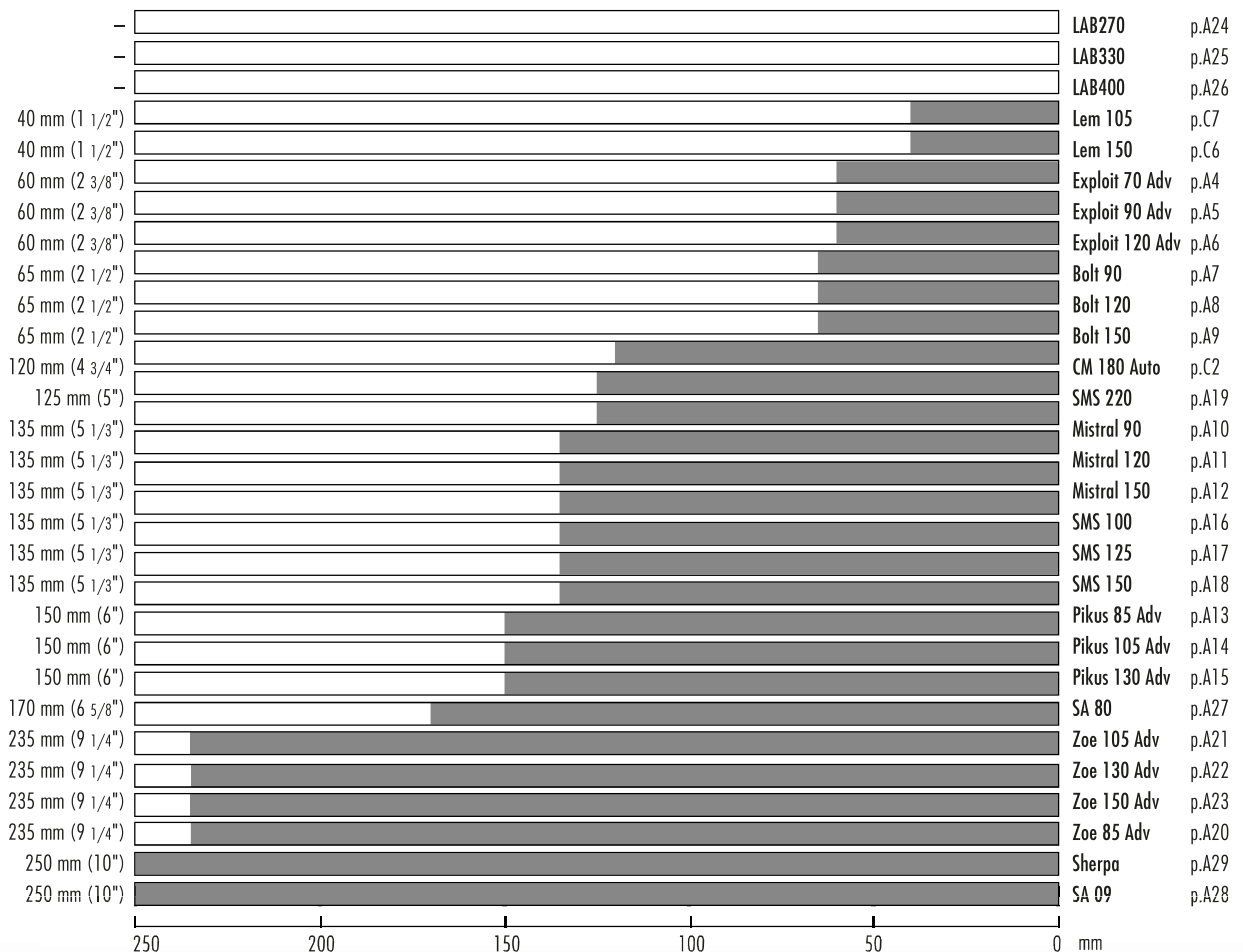



BRIDGE AND JOB SITE SAW MACHINES

EXPLOIT 70



AVAILABLE BLADES

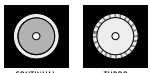

CONTINUAL CROWN DISC TURBO DISC

ACCESSORIES



LEFT 45°/90° SQUARE 90° SQUARE EXTENSION BENCH WITH ROLLERS WHEELS KIT

PACKAGE



CARTON BOX OVERLAPABLE PALLETES

TECHNICAL CHARACTERISTICS

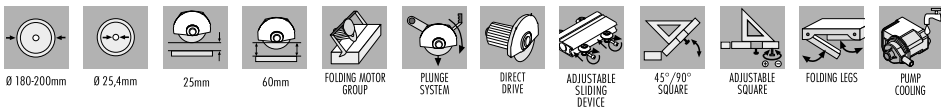

- For cutting porcelain, single-double fired, marble and granite.
- Maximum length of cut 70 cm (27 1/2").
- Maximum depth of cut: 45 mm (1 3/4") in single pass; 60 mm (2 3/8") in double pass.
- Diamond blade: max Ø 200 mm (8"); min Ø 180 mm (7").
- Plunge cut and adjustable cutting depth.
- Heavy Duty water pump.
- Sliding bar and pivots in aluminum.
- Easy-to-remove aluminum work benches for easy cleaning and maximum sturdiness.
- Coated metal frame.
- Re-adjustable aluminum square.

- Motor moves on 4 polypropylene pulleys; each pulley is reinforced with 2 inside bearings.
- Pulleys are easy to re-adjust (tighten): avoid play and confer long lasting precision of cut.
- Motor held by galvanized metal frame.
- Tiling legs.
- Tilting movement (0-47°) for 45° angle cut (jolly).
- Available accessories: self-standing side bench with rollers, 4 wheels + 2 handles kit.
- Supplied with Ø 200 mm (8") continual crown diamond disc for ceramic tiles, user manual, keys kit, dressing stone.

MODEL SPECIFICATIONS

Part No.	Barcode	Box	Lightning Bolt	M	Motor	Motor	Blade	Blade	
393N 070EU	8024648089366	1	230 V 50 Hz	Single-phase	0,9 HP / 0,65 kW	2800	200 mm	8"	2800
393N 070BR	8024648091017	1	230 V 60 Hz	Single-phase	0,9 HP / 0,65 kW	3360	200 mm	8"	3360
393N 070US	8024648089380	1	110 V 60 Hz	Single-phase	0,9 HP / 0,65 kW	3360	200 mm	8"	3360
393N 070GB	8024648089373	1	110 V 50 Hz	Single-phase	0,9 HP / 0,65 kW	2800	200 mm	8"	2800

CUTTING SPECIFICATIONS AND MACHINE DIMENSIONS / WEIGHT

Model	Blade	Blade	Blade	Blade	Blade	Blade	Blade	Blade	Blade	Blade	Blade	Blade	
EXPLOIT 70	200 mm	8"	45 mm	1 3/4"	25 mm	1"	70 cm	∞	49x49 cm	100x56x h50 cm	34 Kg	101x57 h41 cm	36 Kg
	180 mm	7"	35 mm	1 3/8"	-	-	27 1/2"		19 1/2" x 19 1/2"	39 3/8" x 22" x h19 5/8"	75 lbs	39 3/4" x 22 1/2" x h16 1/8"	79.4 lbs





BRIDGE AND JOB SITE SAW MACHINES



AVAILABLE BLADES



CONTINUAL CROWN DISC

TURBO DISC

ACCESSORIES



LEFT 45°/90° SQUARE

90° SQUARE

EXTENSION BENCH WITH ROLLERS

COUNTER SQUARE

WHEELS KIT

PACKAGE



CARTON BOX ON PALLET

OVERLAPPING PALLET

TECHNICAL CHARACTERISTICS

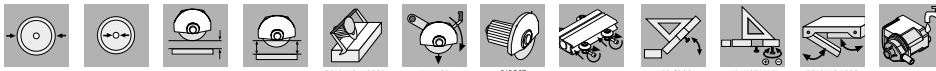

Ø 180-200mm

Ø 25,4mm

25mm

60mm

FOLDING MOTOR GROUP

PLUNGE SYSTEM

DIRECT DRIVE

ADJUSTABLE SLIDING DEVICE

45°/90° SQUARE

ADJUSTABLE SQUARE

FOLDING LEGS

PUMP COOLING

- For cutting porcelain, single-double fired, marble and granite.
- Maximum length of cut 90 cm (35 1/2").
- Maximum depth of cut 45 mm (1 3/4") in single pass; 60 mm (2 3/8") in double pass.
- Diamond blade: max Ø 200 mm (8"); min Ø 180 mm (7").
- Plunge cut and adjustable cutting depth.
- Heavy Duty water pump.
- Sliding bar and pivots in aluminum.
- Easy-to-remove aluminum work benches for easy cleaning and maximum sturdiness.
- Coated metal frame.
- Re-adjustable aluminum square.
- Motor moves on 4 polypropylene pulleys.; each pulley is reinforced with 2 inside bearings.

- Pulleys are easy to re-adjust (tighten): avoid play and confer long lasting precision of cut.
- Motor held by galvanized metal frame.
- Tiling legs.
- Tilting movement (0-47°) for 45° angle cut (jolly).
- Available accessories: extra side square, self-standing side bench with rollers, 4 wheels + 2 handles kit.
- Supplied with Ø 200 mm (8") continual crown diamond disc for ceramic tiles, user manual, keys kit, dressing stone.

MODEL SPECIFICATIONS

Part No.	Barcode	Box	Lightning Bolt	M	Motor	Motor	Blade	Blade	
393N 090EU	8024648089397	1	230 V 50 Hz	Single-phase	0,9 HP / 0,65 kW	2800	200 mm	8"	2800
393N 090BR	8024648091031	1	230 V 60 Hz	Single-phase	0,9 HP / 0,65 kW	3360	200 mm	8"	3360
393N 090US	8024648089410	1	110 V 60 Hz	Single-phase	0,9 HP / 0,65 kW	3360	200 mm	8"	3360
393N 090GB	8024648089403	1	110 V 50 Hz	Single-phase	0,9 HP / 0,65 kW	2800	200 mm	8"	2800

CUTTING SPECIFICATIONS AND MACHINE DIMENSIONS / WEIGHT

Model	Blade	Blade	Blade	Blade	Blade	Blade	Blade	Blade	Blade	Blade	Blade	Blade	
EXPLOIT 90	200 mm	8"	45 mm	1 3/4"	25 mm	1"	90 cm	∞	63x63 cm	125x56x h50 cm	35 Kg	130x58 h55 cm	45 Kg
	180 mm	7"	35 mm	1 3/8"	-	-	35 1/2"		25"x25"	49 1/4"x22"x h19 5/8"	77.2 lbs	51 1/8"x23"x h 21 5/8"	99.2 lbs





BRIDGE AND JOB SITE SAW MACHINES

EXPLOIT 120



AVAILABLE BLADES



CONTINUAL CROWN DISC TURBO DISC

ACCESSORIES



LEFT 45°/90° SQUARE 90° SQUARE EXTENSION BENCH WITH ROLLERS COUNTER SQUARE WHEELS KIT

PACKAGE



WOODEN CASE OVERLAPABLE PALLETES

TECHNICAL CHARACTERISTICS

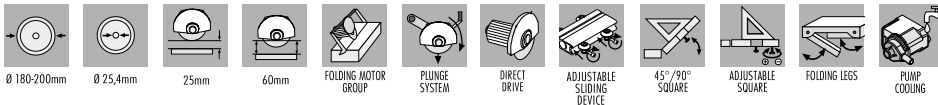

- For cutting porcelain, single-double fired, marble and granite.
- Maximum length of cut 120 cm (47 1/4").
- Maximum depth of cut 45 mm (1 3/4") in single pass; 60 mm (2 3/8") in double pass.
- Diamond blade: max Ø 200 mm (8"); min Ø 180 mm (7").
- Plunge cut and adjustable cutting depth.
- Heavy Duty water pump.
- Sliding bar and pivots in aluminum.
- Easy-to-remove aluminum work benches for easy cleaning and maximum sturdiness.
- Coated metal frame.
- Re-adjustable aluminum square.

- Motor moves on 4 polypropylene pulleys.; each pulley is reinforced with 2 inside bearings.
- Pulleys are easy to re-adjust (tighten): avoid play and confer long lasting precision of cut.
- Motor held by galvanized metal frame.
- Tiling legs.
- Tilting movement (0-47°) for 45° angle cut (jolly).
- Available accessories: extra side square, self-standing side bench with rollers, 4 wheels + 2 handles kit.
- Supplied with Ø 200 mm (8") continual crown diamond disc for ceramic tiles, user manual, keys kit, dressing stone.

MODEL SPECIFICATIONS

Part No.	Barcode	Box	Lightning Bolt	M	Motor	Motor	Blade	Blade
393N 120EU	8024648095664	1	230 V 50 Hz	Single-phase	1,2 HP / 0,9 kW	2800	200 mm 8"	2800
393N 120BR	8024648095893	1	230 V 60 Hz	Single-phase	1,2 HP / 0,9 kW	3360	200 mm 8"	3360
393N 120US	8024648095701	1	110 V 60 Hz	Single-phase	1,2 HP / 0,9 kW	3360	200 mm 8"	3360
393N 120GB	8024648095909	1	110 V 50 Hz	Single-phase	1,2 HP / 0,9 kW	2800	200 mm 8"	2800

CUTTING SPECIFICATIONS AND MACHINE DIMENSIONS / WEIGHT

Model	Blade	Blade	Blade	Blade	Blade	Blade	Blade	Blade	Blade	Blade	Blade	Blade
EXPLOIT 120	200 mm 8"	180 mm 7"	45 mm 1 3/4"	25 mm 1"	60 mm 2 3/8"	120 cm 47 1/4"	∞	85x85 cm 33 1/2"x33 1/2"	155x70xh 50 cm 61"x27"xh 20"	46 Kg 101.4 lbs	165x65xh 55 cm 65"x25 1/2"xh 21 5/8"	62 Kg 136.7 lbs



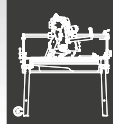

AVAILABLE BLADES

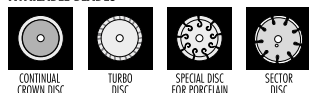

ACCESSORIES

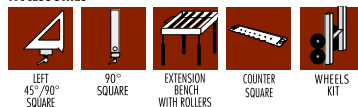

PACKAGE

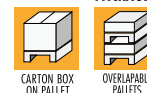

TECHNICAL CHARACTERISTICS

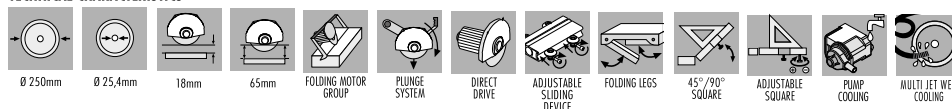

- For cutting porcelain, single-double fired, marble and granite.
- Maximum length of cut 90 cm (35 1/2").
- Maximum depth of cut 55 mm (2 1/8") in single pass; 65 mm (2 1/2") in double pass.
- Diamond blade Ø 250 mm (10").
- Plunge cut and adjustable cutting depth.
- Heavy Duty water pump. High capacity double jet water cooling.
- Sliding bar, pivots and disc cover in aluminum.
- Easy-to-remove aluminum work benches for easy cleaning and maximum sturdiness.
- Coated metal frame.
- Re-adjustable aluminum square.
- Motor moves on 4 polypropylene pulleys.; each pulley is reinforced with 2 inside bearings.

- Pulleys are easy to re-adjust (tighten): avoid play and confer long lasting precision of cut.
- Motor held by galvanized metal frame.
- Tiling legs.
- Tilting movement (0-47°) for 45° angle cut (jolly).
- Available accessories: extra side square, self-standing side bench with rollers, 4 wheels + 2 handles kit.
- Supplied with Ø 250 mm (10") diamond disc for porcelain tiles, user manual, keys kit, dressing stone.

MODEL SPECIFICATIONS

Part No.	Barcode	Box	Lightning Bolt	M	Motor	Motor	Disc	Disc
225MS 90EU	8024648088659	1	230 V 50 Hz	Single-phase	1,5 HP / 1,1 kW	2800	250 mm	10"
225MS 90BR	8024648089717	1	230 V 60 Hz	Single-phase	1,5 HP / 1,1 kW	3360	250 mm	10"
225MS 90US	8024648089731	1	110 V 60 Hz	Single-phase	1,5 HP / 1,1 kW	3360	250 mm	10"
225MS 90GB	8024648089724	1	110 V 50 Hz	Single-phase	1,5 HP / 1,1 kW	2800	250 mm	10"

CUTTING SPECIFICATIONS AND MACHINE DIMENSIONS / WEIGHT

Model	Blade	Depth	Depth	Length	Wheels	Table	Table	Weight	Table	Weight
BOLT 90	250 mm 10"	55 mm 2 1/8"	30 mm 1 3/16"	90 cm 35 1/2"	∞	63x63 cm 25"x25"	120x56x h50 cm 47 1/4"x22"x h19 5/8"	46 Kg 101.4 lbs	130x58xh 55 cm 51 1/8"x23"xh 21 5/8"	56 Kg 123.5 lbs



BOLT 120



AVAILABLE BLADES



CONTINUAL CROWN DISC TURBO DISC SPECIAL DISC FOR PORCELAIN SECTOR DISC

ACCESSORIES



LEFT 45°/90° SQUARE 90° SQUARE EXTENSION BENCH WITH ROLLERS COUNTER SQUARE WHEELS KIT WHEEL KIT FEED

PACKAGE



WOODEN CASE OVERLAPABLE PALLETES

TECHNICAL CHARACTERISTICS

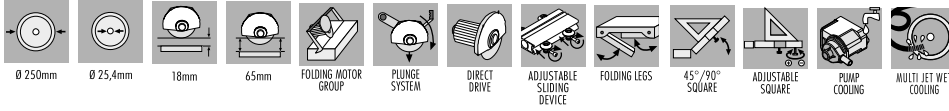

Ø 250mm Ø 25,4mm 18mm 65mm FOLDING MOTOR GROUP PLUNGE SYSTEM DIRECT DRIVE ADJUSTABLE SLIDING DEVICE FOLDING LEGS 45°/90° SQUARE ADJUSTABLE SQUARE PUMP COOLING MULTI JET WET COOLING

- For cutting porcelain, single-double fired, marble and granite.
- Maximum length of cut 120 cm (47 1/4").
- Maximum depth of cut 55 mm (2 1/8") in single pass; 65 mm (2 1/2") in double pass.
- Diamond blade Ø 250 mm (10").
- Plunge cut and adjustable cutting depth.
- Heavy Duty water pump. High capacity double jet water cooling.
- Sliding bar, pivots and disc cover in aluminum.
- Easy-to-remove aluminum work benches for easy cleaning and maximum sturdiness.
- Coated metal frame.
- Re-adjustable aluminum square.
- Motor moves on 4 polypropylene pulleys.; each pulley is reinforced with 2 inside bearings.

- Pulleys are easy to re-adjust (tighten): avoid play and confer long lasting precision of cut.
- Motor held by galvanized metal frame.
- Tiling legs.
- Tilting movement (0-47°) for 45° angle cut (jolly).
- Available accessories: extra side square, self-standing side bench with rollers, 4 wheels + 2 handles kit, wheel feed kit.
- Supplied with Ø 250 mm (10") diamond disc for porcelain tiles, user manual, keys kit, dressing stone.

MODEL SPECIFICATIONS

Part No.	Barcode	Box	Lightning Bolt	M	Motor	Motor	Blade	Blade	
225MS 120EU	8024648088673	1	230 V 50 Hz	Single-phase	1,5 HP / 1,1 kW	2800	250 mm	10"	2800
225MS 120BR	8024648089755	1	230 V 60 Hz	Single-phase	1,5 HP / 1,1 kW	3360	250 mm	10"	3360
225MS 120US	8024648089779	1	110 V 60 Hz	Single-phase	1,5 HP / 1,1 kW	3360	250 mm	10"	3360
225MS 120GB	8024648089762	1	110 V 50 Hz	Single-phase	1,5 HP / 1,1 kW	2800	250 mm	10"	2800

CUTTING SPECIFICATIONS AND MACHINE DIMENSIONS / WEIGHT

Model	Blade Diameter	Max Depth	Min Depth	Max Length	Wheels	Table Size	Table Height	Weight	Table Size	Weight
BOLT 120	250 mm 10"	55 mm 2 1/8"	30 mm 1 3/16"	120 cm 47 1/4"	∞	85x85 cm 33 1/2"x33 1/2"	150x56x h50 cm 59"x22"x h19 5/8"	50 Kg 110.2 lbs	165x65xh 55 cm 65"x25 1/2"xh 21 5/8"	66 Kg 145.5 lbs



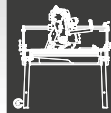

BRIDGE AND JOB SITE SAW MACHINES



AVAILABLE BLADES

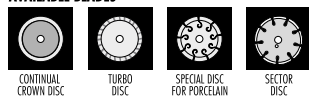

ACCESSORIES

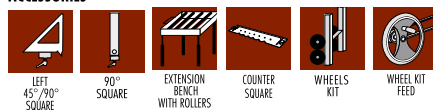

PACKAGE



TECHNICAL CHARACTERISTICS

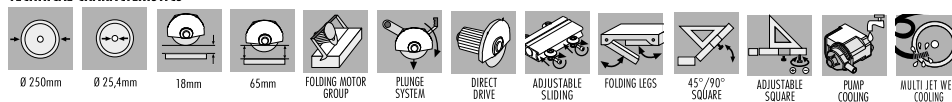

- For cutting porcelain, single-double fired, marble and granite.
- Maximum length of cut 150 cm (59").
- Maximum depth of cut 55 mm (2 1/8") in single pass; 65 mm (2 1/2") in double pass.
- Diamond blade Ø 250 mm (10").
- Plunge cut and adjustable cutting depth.
- Heavy Duty water pump. High capacity double jet water cooling.
- Sliding bar, pivots and disc cover in aluminum.
- Easy-to-remove aluminum work benches for easy cleaning and maximum sturdiness.
- Coated metal frame.
- Re-adjustable aluminum square.

- Motor moves on 4 polypropylene pulleys.; each pulley is reinforced with 2 inside bearings.
- Pulleys are easy to re-adjust (tighten): avoid play and confer long lasting precision of cut.
- Motor held by galvanized metal frame.
- Tiling legs.
- Tilting movement (0-47°) for 45° angle cut (jolly).
- Available accessories: extra side square, self-standing side bench with rollers, 4 wheels + 2 handles kit, wheel feed kit.
- Supplied with Ø 250 mm (10") diamond disc for porcelain tiles, user manual, keys kit, dressing stone.

MODEL SPECIFICATIONS

Part No.	Barcode	Box	Lightning Bolt	M	Motor	Motor	Blade	Blade
225MS 150EU	8024648089809	1	230 V 50 Hz	Single-phase	1,5 HP / 1,1 kW	2800	250 mm 10"	2800
225MS 150BR	8024648089793	1	230 V 60 Hz	Single-phase	1,5 HP / 1,1 kW	3360	250 mm 10"	3360
225MS 150US	8024648089823	1	110 V 60 Hz	Single-phase	1,5 HP / 1,1 kW	3360	250 mm 10"	3360
225MS 150GB	8024648089816	1	110 V 50 Hz	Single-phase	1,5 HP / 1,1 kW	2800	250 mm 10"	2800

CUTTING SPECIFICATIONS AND MACHINE DIMENSIONS / WEIGHT

Model	Blade	Blade	Blade	Blade	Blade	Blade	Blade	Blade	Blade	
BOLT 150	250 mm 10"	55 mm 2 1/8"	30 mm 1 3/16"	150 cm 59"	∞	105x105 cm 41 3/8" x 41 3/8"	180x56X h50 cm 71"x22"x h19 5/8"	56 Kg 123.5 lbs	195x65x h55 cm 76 3/4"x25 1/2"x h 21 5/8"	72 Kg 158.7 lbs



MISTRAL 90



AVAILABLE BLADES



CONTINUAL CROWN DISC TURBO DISC SPECIAL DISC FOR PORCELAIN SECTOR DISC

ACCESSORIES



LEFT 45°/90° SQUARE 90° SQUARE EXTENSION BENCH WITH ROLLERS COUNTER SQUARE WHEELS KIT INCREASED FLANGES Ø 200 mm

PACKAGE



CARTON BOX ON PALLET OVERLAPABLE PALLETS

TECHNICAL CHARACTERISTICS

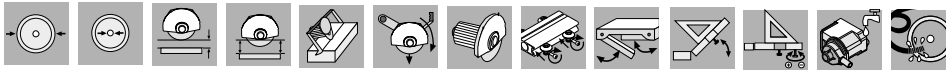

Ø 300-360mm Ø 25,4mm 35mm 135mm FOLDING MOTOR GROUP PLUNGE SYSTEM DIRECT DRIVE ADJUSTABLE SLIDING DEVICE FOLDING LEGS 45°/90° SQUARE ADJUSTABLE SQUARE PUMP COOLING MULTI JET WET COOLING

- For cutting porcelain, single-double fired, marble and granite.
- Maximum length of cut 90 cm (35 1/2").
- Maximum depth of cut 100 mm (4") in single pass; 135 mm (5 1/8") in double pass.
- Diamond blade max Ø 350 mm (14"); min Ø 300 mm (12").
- Plunge cut and adjustable cutting depth.
- Heavy Duty water pump. High capacity double jet water cooling.
- Sliding bar and disc cover in aluminum.
- Easy-to-remove aluminum work benches for easy cleaning and maximum sturdiness.
- Coated metal frame.
- Re-adjustable aluminum square.
- Motor moves on 4 polypropylene pulleys; each pulley is reinforced with 2 inside bearings.

- Pulleys are easy to re-adjust (tighten): avoid play and confer long lasting precision of cut.
- Motor assembly holder and pivots in galvanized steel.
- Tiling legs.
- Tilting movement (0-47°) for 45° angle cut (jolly).
- Available accessories: extra side square, self-standing side bench with rollers, 4 wheels + 2 handles kit.
- Supplied with Ø 350 mm (14") diamond disc for porcelain tiles, user manual, keys kit, dressing stone.

MODEL SPECIFICATIONS

Part No.	Barcode	Box	Lightning Bolt	M	Motor	Motor	Blade	Blade
224MS 90EU	8024648088611	1	230V 50 Hz	Single-phase	3 HP / 2,2 kW	2800	300 mm	12"
224MS 90BR	8024648090492	1	230V 60 Hz	Single-phase	3 HP / 2,2 kW	3360	300 mm	12"
224MS 90US	8024648090508	1	110V 60 Hz	Single-phase	2 HP / 1,5 kW	3360	300 mm	12"

CUTTING SPECIFICATIONS AND MACHINE DIMENSIONS / WEIGHT

Model	Blade	Blade	Blade	Blade	Blade	Blade	Blade	Blade	Blade	Blade			
MISTRAL 90	350 mm	14"	100 mm	4"	60 mm	2 3/8"	90 cm	∞	63x63 cm	120x60x h60 cm	60 Kg	130x58x h72 cm	70 Kg
	300 mm	12"	60 mm	2 3/8"	45 mm	1 3/4"	35 1/2"		25"x25"	47 1/4"x23 5/8"x h23 5/8"	132.3 lbs	51 1/8"x22 3/4"x h 28 3/8"	154.3 lbs





BRIDGE AND JOB SITE SAW MACHINES



AVAILABLE BLADES



CONTINUAL CROWN DISC TURBO DISC SPECIAL DISC FOR PORCELAIN SECTOR DISC

ACCESSORIES



LEFT 45°/90° SQUARE 90° SQUARE EXTENSION BENCH WITH ROLLERS COUNTER SQUARE WHEELS KIT WHEEL KIT FEED INCREASED FLANGES Ø 200 mm

PACKAGE



WOODEN CASE OVERLAPABLE PALLETS

TECHNICAL CHARACTERISTICS

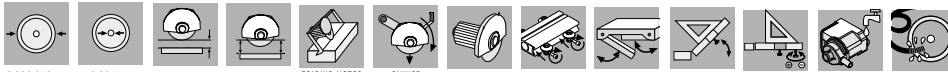

Ø 300-360mm Ø 25,4mm 35mm 135mm FOLDING MOTOR GROUP PLUNGE SYSTEM DIRECT DRIVE ADJUSTABLE SLIDING DEVICE FOLDING LEGS 45°/90° SQUARE ADJUSTABLE SQUARE PUMP COOLING MULTI JET WET COOLING

- For cutting porcelain, single-double fired, marble and granite.
- Maximum length of cut 120 cm (47 1/4").
- Maximum depth of cut 100 mm (4") in single pass; 135 mm (5 1/3") in double pass.
- Diamond blade max Ø 350 mm (14"); min Ø 300 mm (12").
- Plunge cut and adjustable cutting depth.
- Heavy Duty water pump. High capacity double jet water cooling.
- Sliding bar and disc cover in aluminum.
- Easy-to-remove aluminum work benches for easy cleaning and maximum sturdiness.
- Coated metal frame.
- Re-adjustable aluminum square.
- Motor moves on 4 polypropylene pulleys.; each pulley is reinforced with 2 inside bearings.

- Pulleys are easy to re-adjust (tighten): avoid play and confer long lasting precision of cut.
- Motor assembly holder and pivots in galvanized steel.
- Tiling legs.
- Tilting movement (0-47°) for 45° angle cut (jolly).
- Available accessories: extra side square, self-standing side bench with rollers 4 wheels + 2 handles kit, wheel kit feed.
- Supplied with Ø 350 mm (14") diamond disc for porcelain tiles, user manual, keys kit, dressing stone.

MODEL SPECIFICATIONS

Part No.	Barcode	Box	Lightning Bolt	M	Motor	Motor	Disc	Disc	
224MS 120EU	8024648088628	1	230V 50 Hz	Single-phase	3 HP / 2,2 kW	2800	300 mm	12"	2800
224MS 120BR	8024648090522	1	230V 60 Hz	Single-phase	3 HP / 2,2 kW	3360	300 mm	12"	3360
224MS 120US	8024648090539	1	110V 60 Hz	Single-phase	2 HP / 1,5 kW	3360	300 mm	12"	3360

CUTTING SPECIFICATIONS AND MACHINE DIMENSIONS / WEIGHT

Model	Disc	Box	Box	Box	Box	Box	Box	Box	Box	Box	Box
MISTRAL 120	350 mm 14" 300 mm 12"	100 mm 4" 60 mm 2 3/8"	60 mm 2 3/8" 45 mm 1 3/4"	120 cm 47 1/4"	∞	85x85 cm 33 1/2"x 33 1/2"	150x60x h60 cm 59"x23 5/8"x h23 5/8"	63 Kg 138.9 lbs	165x65x h72 cm 65"x25 1/2"x h 28 3/8"	83 Kg 183 lbs	





BRIDGE AND JOB SITE SAW MACHINES

MISTRAL 150



AVAILABLE BLADES

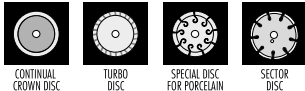

ACCESSORIES

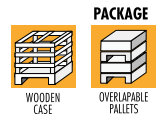
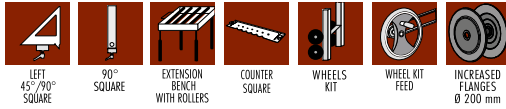

TECHNICAL CHARACTERISTICS

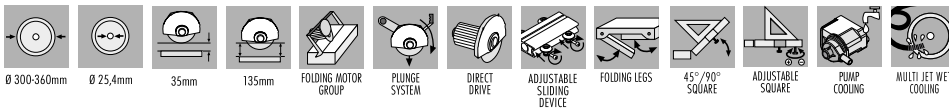

- For cutting porcelain, single-double fired, marble and granite.
- Maximum length of cut 150 cm (59").
- Maximum depth of cut 100 mm (4") in single pass; 135 mm (5 1/3") in double pass.
- Diamond blade max Ø 350 mm (14"); min Ø 300 mm (12").
- Plunge cut and adjustable cutting depth.
- Heavy Duty water pump. High capacity double jet water cooling.
- Sliding bar and disc cover in aluminum.
- Easy-to-remove aluminum work benches for easy cleaning and maximum sturdiness.
- Coated metal frame.
- Re-adjustable aluminum square.
- Motor moves on 4 polypropylene pulleys.; each pulley is reinforced with 2 inside bearings.

- Pulleys are easy to re-adjust (tighten): avoid play and confer long lasting precision of cut.
- Motor assembly holder and pivots in galvanized steel.
- Tiling legs.
- Tilting movement (0-47°) for 45° angle cut (jolly).
- Available accessories: extra side square, self-standing side bench with rollers 4 wheels + 2 handles kit, wheel kit feed.
- Supplied with ø 350 mm (14") diamond disc for porcelain tiles, user manual, keys kit, dressing stone.

MODEL SPECIFICATIONS

Part No.	Barcode	Box	Lightning Bolt	M	Motor	Motor	Blade	Blade	
224MS 150EU	8024648088635	1	230V 50 Hz	Single-phase	3 HP / 2,2 kW	2800	300 mm	12"	2800
224MS 150BR	8024648090553	1	230V 60 Hz	Single-phase	3 HP / 2,2 kW	3360	300 mm	12"	3360
224MS 150US	8024648090560	1	110V 60 Hz	Single-phase	2 HP / 1,5 kW	3360	300 mm	12"	3360

CUTTING SPECIFICATIONS AND MACHINE DIMENSIONS / WEIGHT

Model	Blade	Blade	Blade	Blade	Blade	Blade	Blade	Blade	Blade	Blade			
MISTRAL 150	350 mm	14"	100 mm	4"	60 mm	2 3/8"	150 cm	∞	105x105 cm	180x60x h60 cm	73 Kg	195x65x h72 cm	90 Kg
	300 mm	12"	60 mm	2 3/8"	45 mm	1 3/4"	59"		41 3/8" x 41 3/8"	71"x23 5/8" x h23 5/8"	160.9 lbs	77"x25 1/2" x h 28 3/8"	198.4 lbs





BRIDGE AND JOB SITE SAW MACHINES

AVAILABLE BLADES

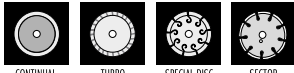

TECHNICAL CHARACTERISTICS

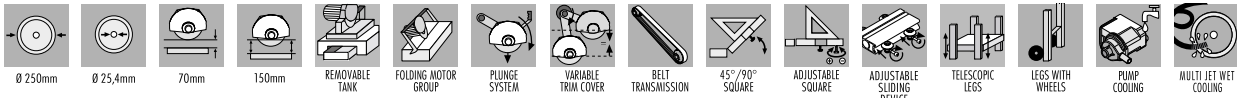

ACCESSORIES



PACKAGE



- For cutting granite, marble, porcelain, single and double fired, bricks, cement, etc. . .
- Maximum length of cut 85 cm (33 1/2").
- Maximum thickness of cut: 80 mm (3 1/8") in single pass; 150 mm (6") in double pass.
- Maximum blade diameter Ø 250 mm (10"); smallest blade diameter Ø 230 mm (9").
- Adjustable cutting depth.
- Tilting motor assembly for bevel cuts from 0° to 45°.
- Belt driven system optimizes motor torque and cutting capacity.
Gear ratio of motor to disc 1,4 ÷ 1. Drive belt type poly V.
- Cast and extruded aluminum framework.
- Easy-to-remove polypropylene tank for easy cleaning. Capacity: 38 lt (10 Gal).

- Heavy duty water pump and (2) jet nozzles (front or rear mounted) provide superior blade cooling.
- Sliding motor assembly with cast aluminum housing provided with 4 re-adjustable pulleys (double bearings). Extruded aluminum rail.
- Re-adjustable square for long lasting precision.
- Telescopic legs provided with double safety device to prevent collapsing.
- Floating blade guard remains in contact with tile to provide extra safety during operation.
- Pivoting blade guard remains parallel with tile to ensure maximum cutting depth.
- Equipped with: diamond disc Ø 250 mm (10") for porcelain, wheels kit for easy transport, key kit, wrench, manual.

MODEL SPECIFICATIONS

Part No.	Barcode	Box	Lightning Bolt	M	Motor	Motor	Blade	Blade	
424ADV	8024648054791	1	230 V 50Hz	Single-phase	1,5 HP / 1,1 kW	2800	250 mm	10"	2000
424ADV 60SX	8050532011083	1	230 V 60Hz	Single-phase	1,5 HP / 1,1 kW	3360	250 mm	10"	2400
424ADV USSX	8050532009073	1	110 V 60Hz	Single-phase	1,3 HP / 1 kW	3360	250 mm	10"	2400
424ADV GBSX	8024648093448	1	115 V 50Hz	Single-phase	1,5 HP / 1,1 kW	2800	250 mm	10"	2000

CUTTING SPECIFICATIONS AND MACHINE DIMENSIONS / WEIGHT

Model	Blade	Thickness	Thickness	Length	Length	Table	Table	Weight	Weight	Weight
PIKUS 85 ADV	250 mm 10"	80 mm 3 1/8"	55 mm 2 1/8"	85 cm 33 1/2"	∞	60x60 cm 23 5/8"x23 5/8"	125x70xh 79 cm 50"x27"x h 31"	60 Kg 132.3 lbs	150x73xh 95cm 59"x29"x h 37"	78 Kg 172 lbs





BRIDGE AND JOB SITE SAW MACHINES

PIKUS 105 ADVANCED



AVAILABLE BLADES

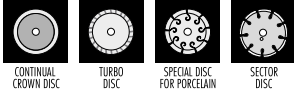

TECHNICAL CHARACTERISTICS

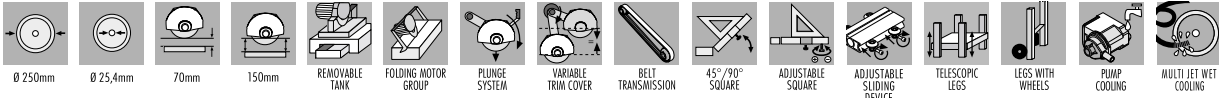

ACCESSORIES

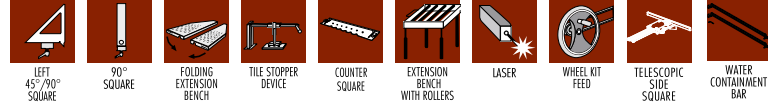

PACKAGE

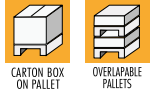

- For cutting granite, marble, porcelain, single and double fired, bricks, cement, etc. . .
- Maximum length of cut 105 cm (41 3/8").
- Maximum thickness of cut: 80 mm (3 1/8") in single pass; 150 mm (6") in double pass.
- Maximum blade diameter Ø 250 mm (10"); smallest blade diameter Ø 230 mm (9").
- Adjustable cutting depth.
- Tilting motor assembly for bevel cuts from 0° to 45°.
- Belt driven system optimizes motor torque and cutting capacity. Gear ratio of motor to disc 1,4 ÷ 1. Drive belt type poly V.
- Cast and extruded aluminum framework.

- Easy-to-remove polypropylene tank for easy cleaning. Capacity: 38 lt (10 Gal).
- Heavy duty water pump and (2) jet nozzles (front or rear mounted) provide superior blade cooling.
- Sliding motor assembly with cast aluminum housing provided with 4 re-adjustable pulleys (double bearings). Extruded aluminum rail.
- Re-adjustable square for long lasting precision.
- Telescopic legs provided with double safety device to prevent collapsing.
- Floating blade guard remains in contact with tile to provide extra safety during operation.
- Pivoting blade guard remains parallel with tile to ensure maximum cutting depth.
- Equipped with: diamond disc Ø 250 mm (10") for porcelain, wheels kit for easy transport, key kit, wrench, manual.

MODEL SPECIFICATIONS

Part No.	Barcode	Box	Lightning Bolt	M	Motor	Motor	Blade	Blade	Blade
423ADV	8024648055163	1	230 V 50Hz	Single-phase	1,5 HP / 1,1 kW	2800	250 mm	10"	2000
423ADV 60SX	8050532011069	1	230 V 60Hz	Single-phase	1,5 HP / 1,1 kW	3360	250 mm	10"	2400
423ADV USSX	8050532009066	1	110 V 60Hz	Single-phase	1,3 HP / 1 kW	3360	250 mm	10"	2400
423ADV GBSX	8024648083142	1	115 V 50Hz	Single-phase	1,5 HP / 1,1 kW	2800	250 mm	10"	2000

CUTTING SPECIFICATIONS AND MACHINE DIMENSIONS / WEIGHT

Model	Blade	Thickness	Thickness	Length	Width	Height	Weight	Dimensions	Weight	
PIKUS 105 ADV	250 mm 10"	80 mm 3 1/8"	55 mm 2 1/8"	105 cm 41 3/8"	∞	75x75 cm 29 1/2"x29 1/2"	145x70xh 79 cm 57"x27"x h 31"	64 Kg 141 lbs	150x73xh 95cm 59"x29"x h 37"	82 Kg 181 lbs





BRIDGE AND JOB SITE SAW MACHINES

AVAILABLE BLADES

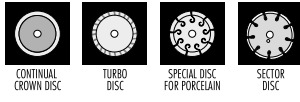

ACCESSORIES

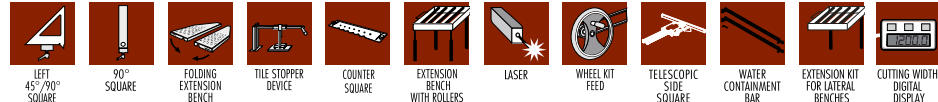

PACKAGE



TECHNICAL CHARACTERISTICS

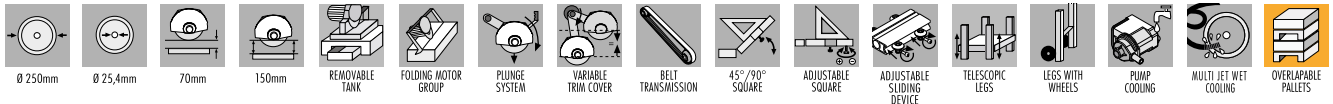

- For cutting granite, marble, porcelain, single and double fired, bricks, cement, etc. . .
- Maximum length of cut 130 cm (51 1/8").
- Maximum thickness of cut: 80 mm (3 1/8") in single pass; 150 mm (6") in double pass.
- Maximum blade diameter Ø 250 mm (10"); smallest blade diameter Ø 230 mm (9").
- Adjustable cutting depth.
- Tilting motor assembly for bevel cuts from 0° to 45°.
- Belt driven system optimizes motor torque and cutting capacity.
Gear ratio of motor to disc 1,4 ÷ 1. Drive belt type poly V.
- Cast and extruded aluminum framework.
- Easy-to-remove polypropylene tank for easy cleaning. Capacity: 38 lt (10 Gal).
- Heavy duty water pump and (2) jet nozzles (front or rear mounted) provide superior blade cooling.
- Sliding motor assembly with cast aluminum housing provided with 4 re-adjustable pulleys (double bearings). Extruded aluminum rail.
- Re-adjustable square for long lasting precision.
- Telescopic legs provided with double safety device to prevent collapsing.
- Floating blade guard remains in contact with tile to provide extra safety during operation.
- Pivoting blade guard remains parallel with tile to ensure maximum cutting depth.
- Equipped with: diamond disc Ø 250 mm (10") for porcelain, wheels kit for easy transport, key kit, wrench, manual.

MODEL SPECIFICATIONS

Part No.	Barcode	Box	Lightning Bolt	M	Motor	Motor	Blade	Blade	Blade
425ADV	8024648055170	1	230 V 50 Hz	Single-phase	1,5 HP / 1,1 kW	2800	250 mm	10"	2000
425ADV 60SX	8050532011090	1	230 V 60 Hz	Single-phase	1,5 HP / 1,1 kW	3360	250 mm	10"	2400
425ADV USSX	8050532009080	1	110 V 60 Hz	Single-phase	1,3 HP / 1 kW	3360	250 mm	10"	2400
425ADV GBSX	8024648085290	1	110 V 50 Hz	Single-phase	1,5 HP / 1,1 kW	2800	250 mm	10"	2000

CUTTING SPECIFICATIONS AND MACHINE DIMENSIONS / WEIGHT

Model	Blade	Thickness	Thickness	Length	Rollers	Table	Table	Weight	Dimensions	Weight
PIKUS 130 ADV	250 mm 10"	80 mm 3 1/8"	55 mm 2 1/8"	130 cm 51 1/8"	∞	90 x 90 cm 35 3/8"x35 3/8"	170x70xh 79 cm 68"x27"x h 31"	78 Kg 172 lbs	200x80xh 110cm 78 3/4"x31 1/2"x h 43 3/8"	119 Kg 264.4 lbs





BRIDGE AND JOB SITE SAW MACHINES

SMS 100



AVAILABLE BLADES

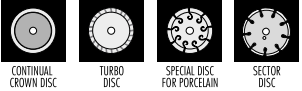

ACCESSORIES

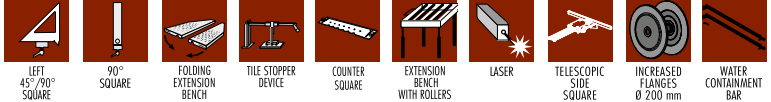

PACKAGE

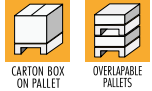

TECHNICAL CHARACTERISTICS

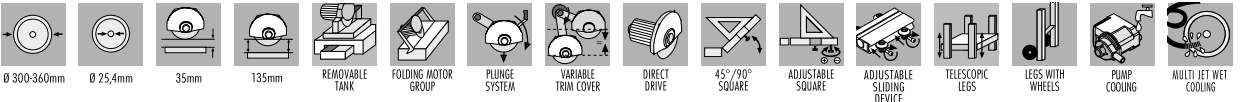

- For cutting granite, marble, porcelain, single and double fired, bricks, cement etc...
- Maximum length of cut 100 cm (39 3/8").
- Maximum depth of cut 100 mm (4") in single pass; 135 mm (5 1/8") in double pass.
- Diamond blade max Ø 360 mm (14"); min Ø 300 mm (12").
- Plunge cut and adjustable cutting depth.
- Heavy duty water pump and jet nozzles provide superior blade cooling.
- Pivoting blade guard remains parallel with tile to ensure maximum cutting depth.
- Cast and extruded aluminum framework.
- Re-adjustable square for long lasting precision.
- Easy-to-remove polypropylene tank for easy cleaning. Capacity: 38 lt (10 Gal).

- Sliding motor assembly with galvanized steel housing provided with 4 pulleys (double internal bearings each).
- Pulleys are easy to re-adjust (tighten): avoid play and confer long lasting precision of cut.
- Tilting movement (0-47°) for 45° angle cut (jolly).
- Telescopic legs provided with double safety device and wheels kit.
- Equipped with: diamond disc Ø 350 mm (14") for porcelain, wheels kit for easy transport, keys kit, user manual.
- Wide range of accessories available.

MODEL SPECIFICATIONS

Part No.	Barcode	Box	Lightning Bolt	Motor	M	Motor	Motor	Blade	Blade	
223MS100EUP	8050532006690	1	230 V 50 Hz	2P+T / 16A	Single-phase	3 HP / 2,2 kW	2800	300 mm	12"	2800
223MS100V400P	8050532006461	1	400 V 50 Hz	3P+T+N / 16A	Three-phase	3 HP / 2,2 kW	2800	300 mm	12"	2800
223MS100BRP	8050532006829	1	230 V 60 Hz	2P+T / 16A	Single-phase	3 HP / 2,2 kW	3360	300 mm	12"	3360
223MS100USP	8050532006836	1	110 V 60 Hz	2P+T / 16A + UL	Single-phase	2 HP / 1,5 kW	3360	300 mm	12"	3360

CUTTING SPECIFICATIONS AND MACHINE DIMENSIONS / WEIGHT

Model	Blade	Blade	Blade	Blade	Blade	Blade	Blade	Blade	Blade	Blade	Blade	Blade
SMS 100	350 mm	14"	100 mm	4"	60 mm	2 3/8"	100 cm	∞	70x70 cm	147x70xh85 cm	80 Kg	150x73x h95 cm
	300 mm	12"	60 mm	2 3/8"	45 mm	1 3/4"	39 3/8"	∞	27 1/2" x 27 1/2"	58"x27 1/2"xh 33 1/2"	176.4 lbs	59"x29" x h37"

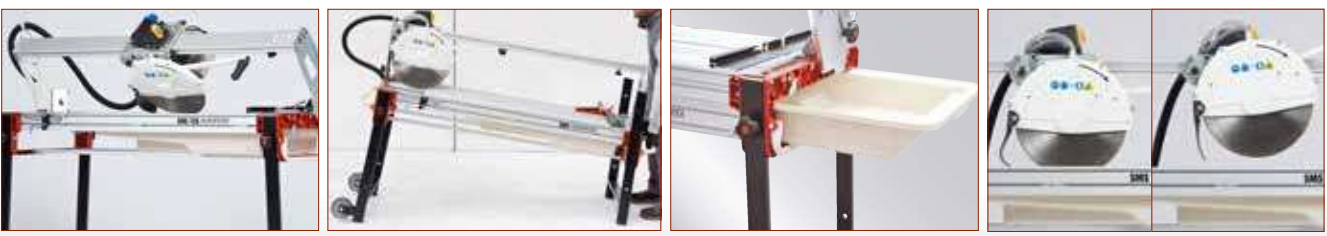

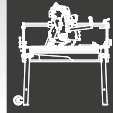

BRIDGE AND JOB SITE SAW MACHINES



AVAILABLE BLADES

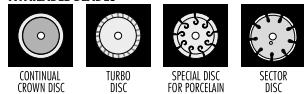

ACCESSORIES



PACKAGE



TECHNICAL CHARACTERISTICS

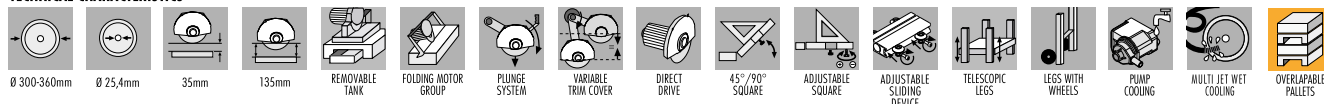

- For cutting granite, marble, porcelain, single and double fired, bricks, cement etc...
- Maximum length of cut 125 cm (49 1/4").
- Maximum depth of cut 100 mm (4") in single pass; 135 mm (5 1/8") in double pass.
- Diamond blade max Ø 360 mm (14"); min Ø 300 mm (12").
- Plunge cut and adjustable cutting depth.
- Heavy duty water pump and jet nozzles provide superior blade cooling.
- Pivoting blade guard remains parallel with tile to ensure maximum cutting depth.
- Cast and extruded aluminum framework.
- Re-adjustable square for long lasting precision.
- Easy-to-remove polypropylene tank for easy cleaning. Capacity: 38 lt (10 Gal).

- Sliding motor assembly with galvanized steel housing provided with 4 pulleys (double internal bearings each).
- Pulleys are easy to re-adjust (tighten): avoid play and confer long lasting precision of cut.
- Tilting movement (0-47°) for 45° angle cut (jolly).
- Telescopic legs provided with double safety device and wheels kit.
- Equipped with: diamond disc Ø 350 mm (14") for porcelain, wheels kit for easy transport, keys kit, user manual.
- Wide range of accessories available.

MODEL SPECIFICATIONS

Part No.	Barcode	Box	Lightning Bolt	Motor Icon	Motor Type	Motor Power	Motor Speed	Blade Size	Blade Diameter
223MS125EUP	8050532006706	1	230 V 50Hz	Blue	2P+T / 16A	Single-phase	3 HP / 2,2 kW	2800	300 mm / 12"
223MS125V400P	8050532006478	1	400 V 50 Hz	Red	3P+T+N / 16A	Three-phase	3 HP / 2,2 kW	2800	300 mm / 12"
223MS125BRP	8050532006843	1	230 V 60Hz	Blue	2P+T / 16A	Single-phase	3 HP / 2,2 kW	3360	300 mm / 12"
223MS125USP	8050532006850	1	110 V 60Hz	Blue	2P+T / 16A + UL	Single-phase	2 HP / 1,5 kW	3360	300 mm / 12"

CUTTING SPECIFICATIONS AND MACHINE DIMENSIONS / WEIGHT

Model	Blade Size	Table Height	Table Width	Table Depth	Table Length	Table Extension	Table Weight	Machine Weight	Machine Dimensions	Machine Weight
SMS 125	350 mm / 14" 300 mm / 12"	100 mm / 4" 60 mm / 2 3/8"	60 mm / 2 3/8" 45 mm / 1 3/4"	125 cm / 49 1/4"	∞	88x88 cm / 34 5/8" x 34 5/8"	175x70x85 cm / 69"x27 1/2"xh 33 1/2"	84 Kg / 185.2 lbs	200x80xh110 cm / 78 3/4"x31 1/2"xh 43 3/8"	125 Kg / 275.6 lbs





SMS 150



AVAILABLE BLADES

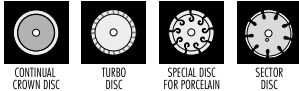

ACCESSORIES

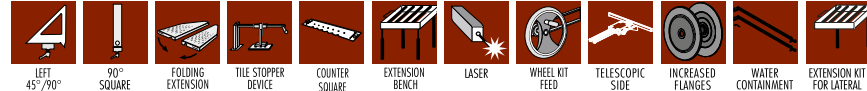

PACKAGE



TECHNICAL CHARACTERISTICS

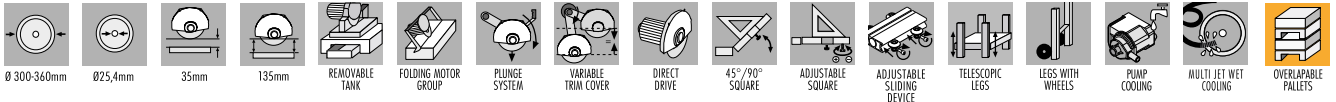

- For cutting granite, marble, porcelain, single and double fired, bricks, cement etc...
- Maximum length of cut 150 cm (59").
- Maximum depth of cut 100 mm (4") in single pass; 135 mm (5 1/8") in double pass.
- Diamond blade max Ø 360 mm (14"); min Ø 300 mm (12").
- Plunge cut and adjustable cutting depth.
- Heavy duty water pump and jet nozzles provide superior blade cooling.
- Pivoting blade guard remains parallel with tile to ensure maximum cutting depth.
- Cast and extruded aluminum framework.
- Re-adjustable square for long lasting precision.
- Easy-to-remove polypropylene tank for easy cleaning. Capacity: 38 lt (10 Gal).
- Sliding motor assembly with galvanized steel housing provided with 4 pulleys (double internal bearings each).
- Pulleys are easy to re-adjust (tighten): avoid play and confer long lasting precision of cut.
- Tilting movement (0-47°) for 45° angle cut (jolly).
- Telescopic legs provided with double safety device and wheels kit.
- Equipped with: diamond disc Ø 350 mm (14") for porcelain tiles, wheels kit for easy transport, keys kit, user manual.
- Wide range of accessories available.

MODEL SPECIFICATIONS

Part No.	Barcode	Box	Lightning Bolt	Motor	M	Motor	Motor	Blade	Blade	
223MS150EUP	8050532002760	1	230 V 50 Hz	2P+T / 16A	Single-phase	3 HP / 2,2 kW	2800	300 mm	12"	2800
223MS150V400	8050532005471	1	400 V 50 Hz	3P+T+N / 16A	Three-phase	3 HP / 2,2 kW	2800	300 mm	12"	2800
223MS150BRP	8050532002753	1	230 V 60 Hz	2P+T / 16A	Single-phase	3 HP / 2,2 kW	3360	300 mm	12"	3360
223MS150USP	8050532002777	1	110 V 60 Hz	2P+T / 16A + UL	Single-phase	2 HP / 1,5 kW	3360	300 mm	12"	3360

Model	Blade	Blade	Blade	Blade	Blade	Blade	Blade	Blade	Blade	Blade	Blade		
SMS 150	350 mm	14"	100 mm	4"	60 mm	2 3/8"	150 cm	∞	106x106 cm	200x70x85 cm	89 Kg	200x80x110 cm	130 Kg
	300 mm	12"	60 mm	2 3/8"	45 mm	1 3/4"	59"	∞	41 5/8" x 41 5/8"	78 3/4" x 27 1/2" x 33 1/2"	196.2 lbs	78 3/4" x 31 1/2" x 43 3/8"	286.6 lbs



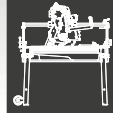

BRIDGE AND JOB SITE SAW MACHINES



AVAILABLE BLADES



ACCESSORIES

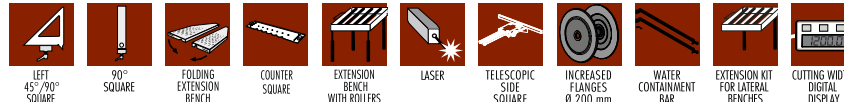

PACKAGE



TECHNICAL CHARACTERISTICS

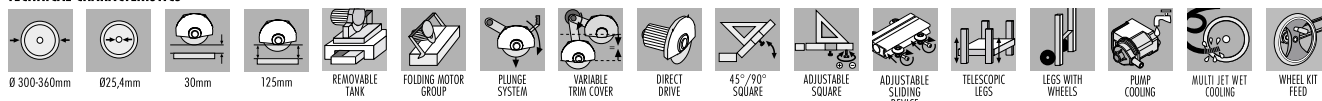

- For cutting granite, marble, porcelain, single and double fired, bricks, cement etc...
- Maximum length of cut 220 cm (86 2/3").
- Maximum depth of cut 90 mm (3 1/2") in single pass; 125 mm (4") in double pass.
- Diamond blade max Ø 360 mm (14"); min Ø 300 mm (12").
- Plunge cut and adjustable cutting depth.
- Heavy duty water pump and jet nozzles provide superior blade cooling.
- Water jet near to the cutting point for an optimal cooling.
- Pivoting blade guard remains parallel with tile to ensure maximum cutting depth.
- Cast and extruded aluminum framework.
- Re-adjustable square for long lasting precision.
- Easy-to-remove polypropylene tank for easy cleaning. Capacity: 38 lt (10 Gal).

- Sliding motor assembly with galvanized steel housing provided with 4 pulleys (double internal bearings each).
- Pulleys are easy to re-adjust (tighten): avoid play and confer long lasting precision of cut.
- Tilting movement (0-47°) for 45° angle cut (jolly).
- Equipped with the motor feed system with wheel kit.
- Telescopic legs provided with double safety device and wheels kit.
- Equipped with: diamond disc Ø 350 mm (14") for porcelain tiles, wheel kit feed, wheels kit for easy transport, keys kit, user manual.
- Wide range of accessories available.

MODEL SPECIFICATIONS

Part No.	Barcode	Box	Lightning Bolt	Plug	M	Motor	Motor	Blade	Blade	
223MS200EU	8024648096289	1	230 V 50 Hz	● 2P+T / 16A	Single-phase	3 HP / 2,2 kW	2800	300 mm	12"	2800
223MS200V400	8050532005518	1	400 V 50 Hz	● 3P+T+N / 16A	Three-phase	3 HP / 2,2 kW	2800	300 mm	12"	2800
223MS200BR	8024648096265	1	230 V 60 Hz	● 2P+T / 16A	Single-phase	3 HP / 2,2 kW	3360	300 mm	12"	3360
223MS200US	8024648096302	1	110 V 60 Hz	● 2P+T / 16A + UL	Single-phase	2 HP / 1,5 kW	3360	300 mm	12"	3360

Model	Blade	Blade	Blade	Blade	Blade	Blade	Blade	Blade	Blade	Blade			
SMS 220	350 mm 14"	300 mm 12"	90 mm 3 1/2"	60 mm 2 3/8"	50 mm 2"	45 mm 1 3/4"	220 cm 86 2/3"	∞	155x155 cm 61"x 61"	270x85xh 85 cm 106"x33 1/2"xh 33 1/2"	120 Kg 264.6 lbs	275x85xh 92 cm 108 1/4"x33 1/2"xh 36 1/5"	208 Kg 458.6 lbs



ZOE 85 ADVANCED

BRIDGE AND JOB SITE SAW MACHINES



AVAILABLE BLADES

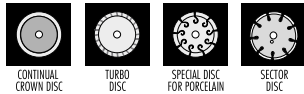

ACCESSORIES



PACKAGE

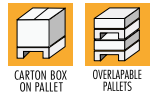

TECHNICAL CHARACTERISTICS

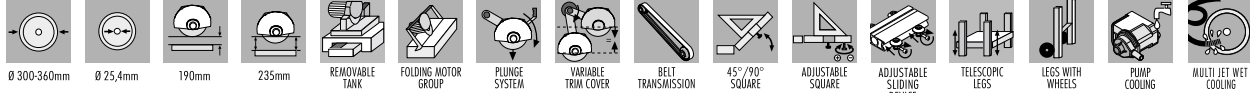

- For cutting granite, marble, porcelain, single and double fired, bricks, cement, etc. . .
- Maximum length of cut 85 cm (33 1/2").
- Maximum thickness of cut: 110 mm (4 1/8") in single pass; 235 mm (9 1/4") in double pass.
- Maximum blade diameter Ø 360 mm (14"); smallest blade diameter Ø 300 mm (12").
- Adjustable cutting depth.
- Tilting motor assembly for bevel cuts from 0° to 45°.
- Belt driven system optimizes motor torque and cutting capacity.
Gear ratio of motor to disc 1,4 ÷ 1. Drive belt type poly V.
- Cast and extruded aluminum framework.
- Easy-to-remove polypropylene tank for easy cleaning. Capacity: 38 lt (10 Gal).

- Heavy duty water pump and (2) jet nozzles provide superior blade cooling.
- Sliding motor assembly with cast aluminum housing provided with 4 re-adjustable pulleys (double bearings). Extruded aluminum rail.
- Re-adjustable square for long lasting precision.
- Telescopic legs provided with safety device to prevent collapsing.
- Pivoting blade guard remains parallel with tile to ensure maximum cutting depth.
- Floating blade guard remains in contact with tile to provide extra safety during operation.
- Equipped with: diamond disc Ø 350 mm (14") for porcelain tiles, wheels kit for easy transport, pressure device to hold tile, key kit, wrench, manual.

MODEL SPECIFICATIONS

Part No.	Barcode	Box	Lightning Bolt	Motor	M	Motor	Motor	Blade	Blade	
42085A P	8050532006744	1	230 V 50 Hz	2P+T / 16A	Single-phase	3 HP/2,2 kW	2800	300 mm	12"	2000
42085A 400VP	8050532006898	1	400 V 50 Hz	3P+T+N / 16A	Three-phase	3 HP/ 2,2 kW	2800	300 mm	12"	2000
42085A 60HZP	8050532006904	1	230 V 60 Hz	2P+T / 16A	Single-phase	3 HP/2,2 kW	3360	300 mm	12"	2400
42085A USP	8050532006874	1	110 V 60 Hz	2P+T / 16A + UL	Single-phase	2,2 HP/1,65 kW	3360	300 mm	12"	2400
42085A GBP	8050532006867	1	110 V 50 Hz	2P+T / 32A	Single-phase	2,2 HP/1,65 kW	2800	300 mm	12"	2000

CUTTING SPECIFICATIONS AND MACHINE DIMENSIONS / WEIGHT

Model	Blade	Blade	Blade	Blade	Blade	Blade	Blade	Blade	Blade	Blade	Blade	Blade	
ZOE 85 ADV	350 mm 300 mm	14" 12"	110 mm 80 mm	4 1/8" 3 1/8"	80 mm 20 mm	3 1/8" 5/32"	85 cm 33 1/2"	∞	60x60 cm 23 5/8"x23 5/8"	125x70xh 95 cm 50"x27"x h 37"	80 Kg 176.4 lbs	150x73xh 110cm 59"x29"x h 43"	98 Kg 216.1 lbs





BRIDGE AND JOB SITE SAW MACHINES

AVAILABLE BLADES

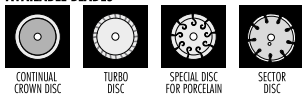

ACCESSORIES

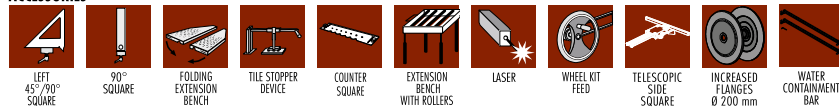

PACKAGE

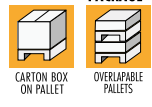

TECHNICAL CHARACTERISTICS

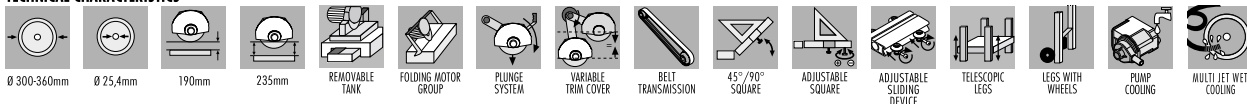

- For cutting granite, marble, porcelain, single and double fired, bricks, cement, etc...
- Maximum length of cut 105 cm (41 3/8").
- Maximum thickness of cut: 110 mm (4 1/8") in single pass; 235 mm (9 1/4") in double pass.
- Maximum blade diameter Ø 360 mm (14"); smallest blade diameter Ø 300 mm (12").
- Adjustable cutting depth.
- Tilting motor assembly for bevel cuts from 0° to 45°.
- Belt driven system optimizes motor torque and cutting capacity. Gear ratio of motor to disc 1,4 ÷ 1. Drive belt type poly V.
- Cast and extruded aluminum framework.

- Easy-to-remove polypropylene tank for easy cleaning. Capacity: 38 lt (10 Gal).
- Heavy duty water pump and (2) jet nozzles provide superior blade cooling.
- Sliding motor assembly with cast aluminum housing provided with 4 re-adjustable pulleys (double bearings). Extruded aluminum rail.
- Re-adjustable square for long lasting precision.
- Telescopic legs provided with safety device to prevent collapsing.
- Pivoting blade guard remains parallel with tile to ensure maximum cutting depth.
- Floating blade guard remains in contact with tile to provide extra safety during operation.
- Equipped with: diamond disc Ø 350 mm (14") for porcelain tiles, wheels kit for easy transport, pressure device to hold tile, key kit, wrench, manual.

MODEL SPECIFICATIONS

Part No.	Barcode	Box	Lightning Bolt	Motor	M	Motor	Motor	Blade	Blade	
420105A P	8050532006508	1	230 V 50 Hz	● 2P+T / 16A	Single-phase	3 HP / 2,2 kW	2800	300 mm	12"	2000
420105A 400VP	8050532006539	1	400 V 50 Hz	● 3P+T+N / 16A	Three-phase	3 HP / 2,2 kW	2800	300 mm	12"	2000
420105A 60HZP	8050532006546	1	230 V 60 Hz	● 2P+T / 16A	Single-phase	3 HP / 2,2 kW	3360	300 mm	12"	2400
420105A USP	8050532006515	1	110 V 60 Hz	● 2P+T / 16A + UL	Single-phase	2,2 HP / 1,65 kW	3360	300 mm	12"	2400
420105A GBP	8050532006492	1	110 V 50 Hz	● 2P+T / 32A	Single-phase	2,2 HP / 1,65 kW	2800	300 mm	12"	2000

CUTTING SPECIFICATIONS AND MACHINE DIMENSIONS / WEIGHT

Model	Blade	Blade	Blade	Blade	Blade	Blade	Blade	Blade	Blade	Blade
ZOE 105 ADV	350 mm / 14"	110 mm / 4 1/8"	80 mm / 3 1/8"	105 cm / 41 3/8"	∞	75x75 cm / 29 1/2"x29 1/2"	145x70xh 95 cm / 57"x27"x h 37"	84 Kg / 185.2 lbs	150x73xh 110cm / 59"x29"x h 43"	102 Kg / 224.9 lbs





BRIDGE AND JOB SITE SAW MACHINES

ZOE 130 ADVANCED



AVAILABLE BLADES

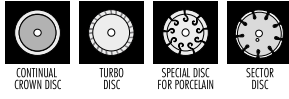

ACCESSORIES

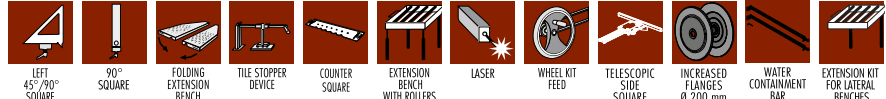

PACKAGE



TECHNICAL CHARACTERISTICS

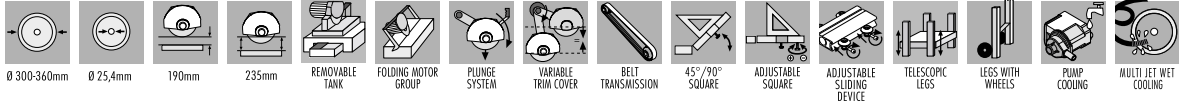

- For cutting granite, marble, porcelain, single and double fired, bricks, cement, etc...
- Maximum length of cut 130 cm (51 1/8").
- Maximum thickness of cut: 110 mm (4 1/8") in single pass; 235 mm (9 1/4") in double pass.
- Maximum blade diameter Ø 360 mm (14"); smallest blade diameter Ø 300 mm (12").
- Adjustable cutting depth.
- Tilting motor assembly for bevel cuts from 0° to 45°.
- Belt driven system optimizes motor torque and cutting capacity.
Gear ratio of motor to disc 1,4 ÷ 1. Drive belt type poly V.
- Cast and extruded aluminum framework.
- Easy-to-remove polypropylene tank for easy cleaning. Capacity: 38 lt (10 Gal).
- Heavy duty water pump and (2) jet nozzles provide superior blade cooling.
- Sliding motor assembly with cast aluminum housing provided with 4 re-adjustable pulleys (double bearings). Extruded aluminum rail.
- Re-adjustable square for long lasting precision.
- Telescopic legs provided with safety device to prevent collapsing.
- Pivoting blade guard remains parallel with tile to ensure maximum cutting depth.
- Floating blade guard remains in contact with tile to provide extra safety during operation.
- Equipped with: diamond disc Ø 350 mm (14") for porcelain tiles, wheels kit for easy transport, pressure device to hold tile, key kit, wrench, manual.

MODEL SPECIFICATIONS

Part No.	Barcode	Box	Lightning Bolt	Motor	M	Motor	Motor	Blade	Blade	
420130A P	8050532006560	1	230 V 50 Hz	● 2P+T / 16A	Single-phase	3 HP/2,2 kW	2800	300 mm	12"	2000
420130A 400VP	8050532006584	1	400 V 50 Hz	● 3P+T+N / 16A	Three-phase	3 HP/ 2,2 kW	2800	300 mm	12"	2000
420130A 60HZP	8050532006591	1	230 V 60 Hz	● 2P+T / 16A	Single-phase	3 HP/2,2 kW	3360	300 mm	12"	2400
420130A USP	8024648056900	1	110 V 60 Hz	● 2P+T / 16A + UL	Single-phase	2,2 HP/1,65 kW	3360	300 mm	12"	2400
420130A GBP	8050532006553	1	110 V 50 Hz	● 2P+T / 32A	Single-phase	2,2 HP/1,65 kW	2800	300 mm	12"	2000

CUTTING SPECIFICATIONS AND MACHINE DIMENSIONS / WEIGHT

Model	Blade	Blade	Blade	Blade	Blade	Blade	Blade	Blade	Blade	Blade	Blade	
ZOE 130 ADV	350 mm 300 mm	14" 12"	110 mm 80 mm	4 1/8" 3 1/8"	80 mm 20 mm	3 1/8" 2 3/8"	130 cm ∞	90x90 cm 35 3/8"x35 3/8"	170x70xh 95 cm 67"x27"x h 37"	98 Kg 216 lbs	200x80xh 110cm 78 3/4"x31 1/2"x h 43"	139 Kg 306.4 lbs





BRIDGE AND JOB SITE SAW MACHINES

AVAILABLE BLADES

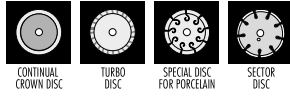

ACCESSORIES

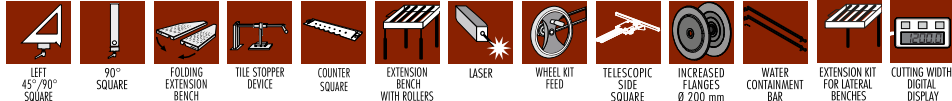

PACKAGE



TECHNICAL CHARACTERISTICS

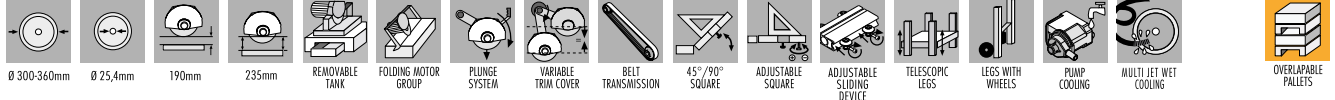

- For cutting granite, marble, porcelain, single and double fired, bricks, cement, etc. . .
- Maximum length of cut: 155 cm (61").
- Maximum thickness of cut: 110 mm (4 1/8") in single pass; 235 mm (9 1/4") in double pass.
- Maximum blade diameter Ø 360 mm (14"); smallest blade diameter Ø 300 mm (12").
- Adjustable cutting depth.
- Tilting motor assembly for bevel cuts from 0° to 45°.
- Belt driven system optimizes motor torque and cutting capacity. Gear ratio of motor to disc 1,4 ÷ 1. Drive belt type poly V.
- Cast and extruded aluminum framework.

- Easy-to-remove polypropylene tank for easy cleaning. Capacity: 38 lt (10 Gal).
- Heavy duty water pump and (2) jet nozzles provide superior blade cooling.
- Sliding motor assembly with cast aluminum housing provided with 4 re-adjustable pulleys (double bearings). Extruded aluminum rail.
- Re-adjustable square for long lasting precision.
- Telescopic legs provided with safety device to prevent collapsing.
- Pivoting blade guard remains parallel with tile to ensure maximum cutting depth.
- Floating blade guard remains in contact with tile to provide extra safety during operation.
- Equipped with: diamond disc Ø 350 mm (14") for porcelain tiles, wheels kit for easy transport, pressure device to hold tile, key kit, wrench, manual.

MODEL SPECIFICATIONS

Part No.	Barcode	Box	Lightning Bolt	Motor	Waveform	Motor	Motor	Blade	Blade	
420150A AP	8050532002692	1	230 V 50 Hz	Blue	Single-phase	3 HP/2,2 kW	2800	300 mm	12"	2000
420150A 400P	8050532002739	1	400 V 50 Hz	Red	Three-phase	3 HP/2,2 kW	2800	300 mm	12"	2000
420150A 60HP	8050532002746	1	230 V 60 Hz	Blue	Single-phase	3 HP/2,2 kW	3360	300 mm	12"	2400
420150A USP	8050532002715	1	110 V 60 Hz	Blue	Single-phase	2,2 HP/1,65 kW	3360	300 mm	12"	2400
420150A GBP	8050532002760	1	110 V 50 Hz	Yellow	Single-phase	2,2 HP/1,65 kW	2800	300 mm	12"	2000

CUTTING SPECIFICATIONS AND MACHINE DIMENSIONS / WEIGHT

Model	Blade	Blade	Blade	Blade	Blade	Blade	Blade	Blade	Blade	Blade	
ZOE 150 ADV	350 mm 14"	110 mm 4 1/8"	80 mm 3 1/8"	80 mm 3 1/8"	155 cm 61"	∞	109x109 cm 42 7/8" x 42 7/8"	200x70x h95 cm 78 3/4" x 27" x h37"	106 Kg 233.7 lbs	200x80x h110 cm 78 3/4" x 31 1/2" x h43"	147 Kg 324 lbs





LAB 270



*Dual side bench with countersquare included

TECHNICAL CHARACTERISTICS

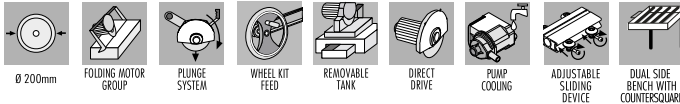

AVAILABLE BLADES

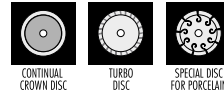

ACCESSORIES

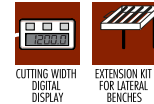

PACKAGE



- For straight and 45° angle cut (miter/"jolly") of porcelain, ceramic, granite, marble, etc.;
- Maximum length of cut: 270 cm (8.85') - of which 10 cm (4") of plunge cut;
- Dual side bench with countersquare included. Accepts tiles from 0 mm to 1610 mm (5.3') width (maximum distance between the line of cut and the counter-cutout: 1610 mm - 5.3'). Expand width up to 3300 mm (10.8') thanks to the dedicate accessory, sold separately (Art. 374BRU 2F2);
- Maximum depth (thickness) of cut 90°/straight cut: 20 mm (0.79") in one single pass;
- Maximum depth (thickness) of cut 45° angle cut/mitre: 20 mm (0.79");
- Plunge cut and adjustable cutting depth;
- Available in 400V three-phase and in 230V single-phase (motor power 2.2 Kw in both versions);
- Water jet pointing at the blade outer diamond rim for superior cooling and best cutting performances;
- Framework made of aluminum (die-cast and extruded) and galvanized steel;
- Easy-to-remove polypropylene tank for easy cleaning. Capacity 38 lt (10 Gal). Immersion pump for water flow (50 liters/minute);

- Maximum load capacity: 300 Kg (661.3 lbs);
- Equipped with the motor feed system with wheel kit;
- Minimum recommended workstation area with machine in standard configuration: 5,5 x 4,5 m (18'x 14.8');
- Minimum recommended workstation area with machine in standard configuration + extension kit for lateral benches - art. 374BRU 2F2, sold separately): 5,5 x 6 m (18'x19.7');
- Equipped with: Ø 200 mm (8") diamond disc for porcelain, wheel kit feed, dual side bench with countersquare, keys kit, user manual;
- Accessories:
 - digital displays kit for cutting width measurement (Art. 374VISVESTD up to 161 cm - 5.3', art.374VISVEMAXI up to 330 cm - 10.8');
 - additional dual side bench (art. 374BRU 2F2) to be connected to those provided with the machine for extending width of cut up to 330 cm - 10.8' (maximum distance between line of cut and countersquare: 330 cm -10.8').

MODEL SPECIFICATIONS

Part No.	Barcode	Box	Lightning Bolt	Motor	M	Motor	Motor	Disc	Disc	
379CA260V400	8050532016019	1	400 V 50 Hz	● 3P+T+N / 16A	Three-phase	3 HP / 2,2 kW	2800	200 mm	8"	2800
379CA260EU	8050532015999	1	230 V 50 Hz	● 2P+T / 16A	Single-phase	3 HP / 2,2 kW	2800	200 mm	8"	2800
379CA260BR	8050532020559	1	230 V 60 Hz	● 2P+T / 16A	Single-phase	3 HP / 2,2 kW	3360	200 mm	8"	3360

CUTTING SPECIFICATIONS AND MACHINE DIMENSIONS / WEIGHT

	Disc	Thickness of cut 90°	Thickness of cut 45°	Length	Width	Width with accessories	Diagonal	Motor	Weight	Dimensions	Weight
LAB 270	200 mm 8"	MAX 20 mm MAX 0.79"	MAX 20 mm MAX 0.79"	MAX 2700 mm MAX 8.85'	MAX 1610 mm MAX 5.3'	MAX 3300 mm MAX 10.8'	1900x1900 mm 6.2'x6.2'	350x170x h 120 cm 11.5'x5.6'x h 3.9'	230 Kg 507 lbs	358x94x h 127 cm 11.7'x3'x h 4.2'	290 Kg 639.3 lbs

ACCESSORIES AND SPARE DIAMOND BLADE

Part No.	Barcode	Box	Description	Additional notes
374VISVESTD	8050532020429	1	Digital display kit for measurement of cutting width up to 1610 mm (5.3').	To be mounted on dual side bench supplied with the machine.
374VISVEMAXI	8050532020412	1	Digital display kit for measurement of cutting width up to 3300 mm (10.8').	To be used only in combination with kit of 2 side benches to extend maximum width of cut up to 3300 mm - 10.8' (Art. 374BRU 2F2 - accessories).
374BRU 2F2	8050532020368	1	To be used only in combination with kit of 2 side benches to extend maximum width of cut up to 3300 mm - 10.8' (Art. 374BRU 2F2 - accessories).	Includes pair of side benches and kit to connect them to the benches supplied with the machine.
179SET200SP	8024648076137	1	200 mm (8") diamond disc for porcelain (inner hole 25,4 mm - 1")	-

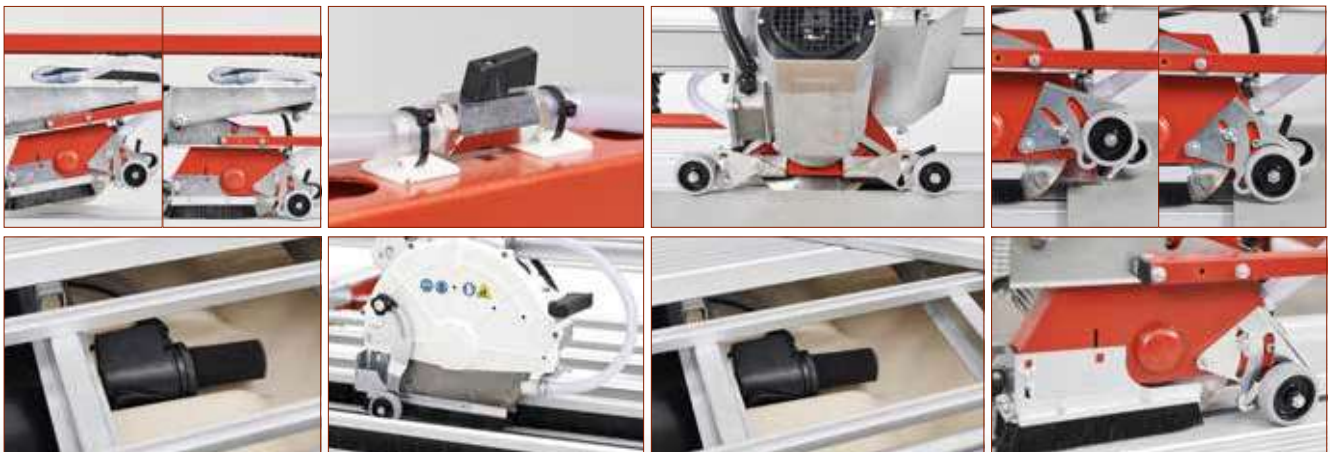

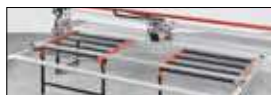
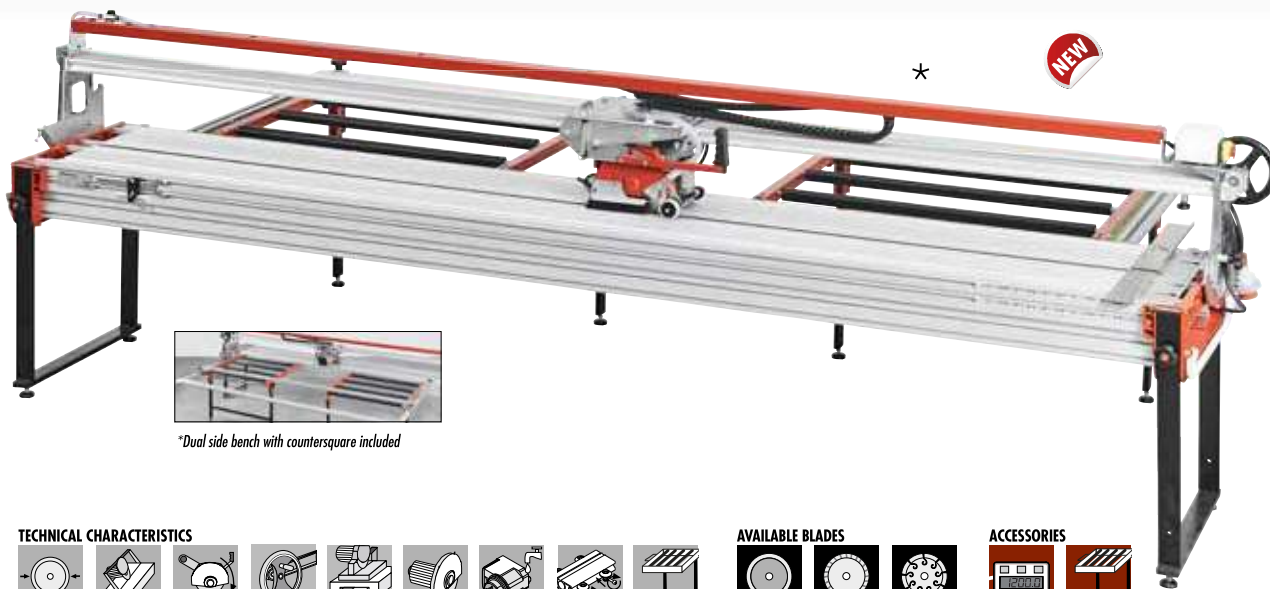
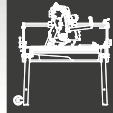

*Dual side bench with countersquare included

TECHNICAL CHARACTERISTICS



AVAILABLE BLADES



ACCESSORIES



PACKAGE



- For straight and 45° angle cut (miter/"jolly") of porcelain, ceramic, granite, marble, etc.;
- Maximum length of cut: 330 cm (10.8') - of which 10 cm (4") of plunge cut;
- Dual side bench with countersquare included. Accepts tiles from 0 mm to 1610 mm (5.3') width (maximum distance between the line of cut and the counter-cutout: 1610 mm - 5.3'). Expand width up to 3300 mm (10.8') thanks to the dedicate accessory, sold separately (Art. 374BRU 2F2);
- Maximum depth (thickness) of cut 90°/straight cut: 20 mm (0.79") in one single pass;
- Maximum depth (thickness) of cut 45° angle cut/mitre: 20 mm (0.79");
- Plunge cut and adjustable cutting depth;
- Available in 400V three-phase and in 230V single-phase (motor power 2.2 Kw in both versions);
- Water jet pointing at the blade outer diamond rim for superior cooling and best cutting performances;
- Framework made of aluminum (die-cast and extruded) and galvanized steel;
- Easy-to-remove polypropylene tank for easy cleaning. Capacity 38 Lt (10 Gal). Immersion pump for water flow (50 liters/minute).
- Maximum load capacity: 300 Kg (661.3 lbs);

- Equipped with the motor feed system with wheel kit;
- Minimum recommended workstation area with machine in standard configuration: 6 x 4,5 m (19.7'x 14.8');
- Minimum recommended workstation area with machine in standard configuration + extension kit for lateral benches - art. 374BRU 2F2, sold separately): 6 x 6 m (19.7'x19.7');
- Equipped with: Ø 200 mm (8") diamond disc for porcelain, wheel kit feed, dual side bench with countersquare, keys kit, user manual;
- Accessories:
 - digital displays kit for cutting width measurement (Art. 374VISVESTD up to 161 cm - 5.3', art.374VISVEMAXI up to 330 cm - 10.8');
 - additional dual side bench (art. 374BRU 2F2) to be connected to those provided with the machine for extending width of cut up to 330 cm - 10.8' (maximum distance between line of cut and countersquare: 330 cm -10.8').

MODEL SPECIFICATIONS

Part No.	Barcode	Box	Lightning Bolt	Motor	M	Motor	Motor	Disc	Disc	
379CA330V400	8050532016057	1	400 V 50 Hz	● 3P+T+N / 16A	Three-phase	3 HP / 2,2 kW	2800	200 mm	8"	2800
379CA330EU	8050532016033	1	230 V 50 Hz	● 2P+T / 16A	Single-phase	3 HP / 2,2 kW	2800	200 mm	8"	2800
379CA330BR	8050532020443	1	230 V 60 Hz	● 2P+T / 16A	Single-phase	3 HP / 2,2 kW	3360	200 mm	8"	3360

CUTTING SPECIFICATIONS AND MACHINE DIMENSIONS / WEIGHT

	Disc	Thickness of cut 90°	Thickness of cut 45°	Length	Width	Width with accessories	Diagonal	Height	Weight	Dimensions	Weight
LAB 330	200 mm 8"	MAX 20 mm MAX 0.79"	MAX 20 mm MAX 0.79"	MAX 3300 mm MAX 10.8'	MAX 1610 mm MAX 5.3'	MAX 3300 mm MAX 10.8'	2330x2330 mm 7.6'x7.6'	400x170x h 120 cm 13.1'x5.6'x h 3.9'	241 Kg 532 lbs	408x94x h 127 cm 13.4'x3'x h 4.2'	315 Kg 695 lbs

ACCESSORIES AND SPARE DIAMOND BLADE

Part No.	Barcode	Box	Description	Additional notes
374VISVESTD	8050532020429	1	Digital display kit for measurement of cutting width up to 1610 mm (5.3').	To be mounted on dual side bench supplied with the machine.
374VISVEMAXI	8050532020412	1	Digital display kit for measurement of cutting width up to 3300 mm (10.8').	To be used only in combination with kit of 2 side benches to extend maximum width of cut up to 3300 mm - 10.8' (Art. 374BRU 2F2 - optional).
374BRU 2F2	8050532020368	1	To be used only in combination with kit of 2 side benches to extend maximum width of cut up to 3300 mm - 10.8' (Art. 374BRU 2F2 - optional).	Includes pair of side benches and kit to connect them to the benches supplied with the machine.
179SET200SP	8024648076137	1	200 mm (8") diamond disc for porcelain (inner hole 25,4 mm - 1")	-

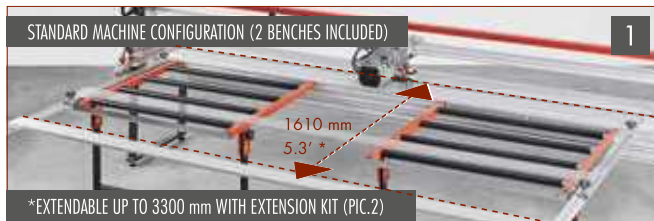

*EXTENDABLE UP TO 3300 mm WITH EXTENSION KIT (PIC.2)



MACHINE + EXTENSION KIT FOR LATERAL BENCHES (4 BENCHES TOT.)



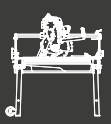

LAB 400



*Dual side bench with countersquare included

TECHNICAL CHARACTERISTICS

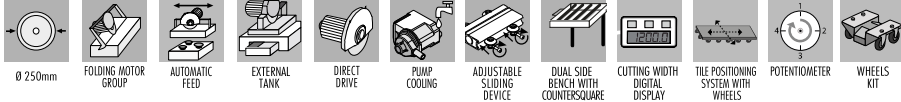

ACCESSORIES



EXTENSION KIT FOR LATERAL BENCHES

PACKAGE



WOODEN CASE

- For straight and 45° angle cut (miter/"jolly") of porcelain, ceramic, granite, marble, etc.;
- Maximum length of cut: 400 cm (13.1') +15 cm (6") when performing plunge cut;
- Dual side bench with countersquare included. Accepts tiles from 0 mm to 1610 mm (5.3') width (maximum distance between the line of cut and the counter-cutout: 1610 mm - 5.3'). Expand width up to 3300 mm (10.8') thanks to the dedicate accessory, sold separately (Art. 374BRU 400);
- Countersquare equipped with double digital display (one on each end of the tile) to measure width of cut and to place tile parallel with the line of cut
- Maximum depth (thickness) of cut 90°/straight cut: 30 mm (1.18");
- Maximum depth (thickness) of cut 45° angle cut/mitre: 20 mm (0.79");
- Available in 400V three-phase (motor power 2.2 Kw);
- Water jet pointing at the blade outer diamond rim for superior cooling and best cutting performances;
- External tank. Capacity 38 lt (10 Gal). Immersion pump for water flow (50 liters/minute).
- Cutting precision guaranteed by the material-pressing wheels systems (both for 90° and 45° cutting ("Jolly");
- Very high resistance to rust: main components in AISI304 stainless steel, structure in extruded aluminum, other parts in steel with cataphoresis treatment and paint or galvanized steel;
- Easy positioning of the slab on the work surface thanks to the 14 omnidirectional wheels that can be operated with a pneumatic system (maximum lifting load 177 Kg evenly distributed on the work surface);
- Automatic advancement system by gearmotor with adjustment of the advancement speed with a potentiometer;
- Control panel equipped with ammeter to check performance during the cutting phase;
- Safety stop device on the whole length of the machine;
- Equipped with: 2 diamond disc for porcelain Ø 250 mm (10"), – one for 3-12 mm (1/8"-1/2") thick tiles, one for 13-30 mm (33/64"- 1 3/16") thick tiles, dual side bench with countersquare, digital display kit for cutting width measurement, tile positioning with pneumatic system omnidirectional wheels, keys kit, user manual.
- Accessories:
 - additional dual side bench to be connected to those provided with the machine for extending width of cut up to 330 cm - 10.8' + magnetic strips to change the position of the digital display of the cutting width (Art. 374BRU 400).
- Requirements:
 - Minimum recommended workstation area with machine in standard configuration: 8x5 m (26.2'x16.4') ; with extension kit for lateral benches: 8x6,5 m (26.2'x21.3') ;
 - Power supply 400V 50Hz Three-phase 5 poles 16 Amp;
 - Compressed air connection (min. 6 bar / max. 10 bar).

MODEL SPECIFICATIONS

Part No.											
379CA400	8050532019676	1	400 V 50 Hz	● 3P+T+N / 16A	Three-phase	3 HP / 2,2 kW	2800	min 6 bar - max 10 bar	250 mm	10"	2800

CUTTING SPECIFICATIONS AND MACHINE DIMENSIONS / WEIGHT

Model											
LAB 400	250 mm 10"	30 mm 1 3/16"	20 mm 13/16"	4000 mm 13 1/8'	1610 mm 5 9/32'	3300 mm 10 53/64'	283x283 cm 9 9/32'x9 9/32'	520x290x h125 cm 205"x115"xh 50"	581 Kg 1281 lbs	531x125x h 160 210"x50"x h 63"	840 Kg 1852 lbs

ACCESSORIES AND SPARE DIAMOND BLADE

Part No.			Description	Additional notes
374BRU 400	8050532020382	1	Kit of 2 side benches to extend maximum width of cut up to 3300 mm (10.8').	Includes pair of side benches and kit to connect them to the benches supplied with the machine + predisposition to adapt digital display of 3300 mm cutting width (comes supplied with the machine).
179SET250SP10	8050532020887	1	Diamond disc for porcelain (inner hole 25,4 mm – 1").	For 3-12 mm (1/8"-1/2") thick tiles.
179SET250SP20	8050532020894	1	Diamond disc for porcelain (inner hole 25,4 mm – 1").	For 13-30 mm (33/64"- 1 3/16") thick tiles.

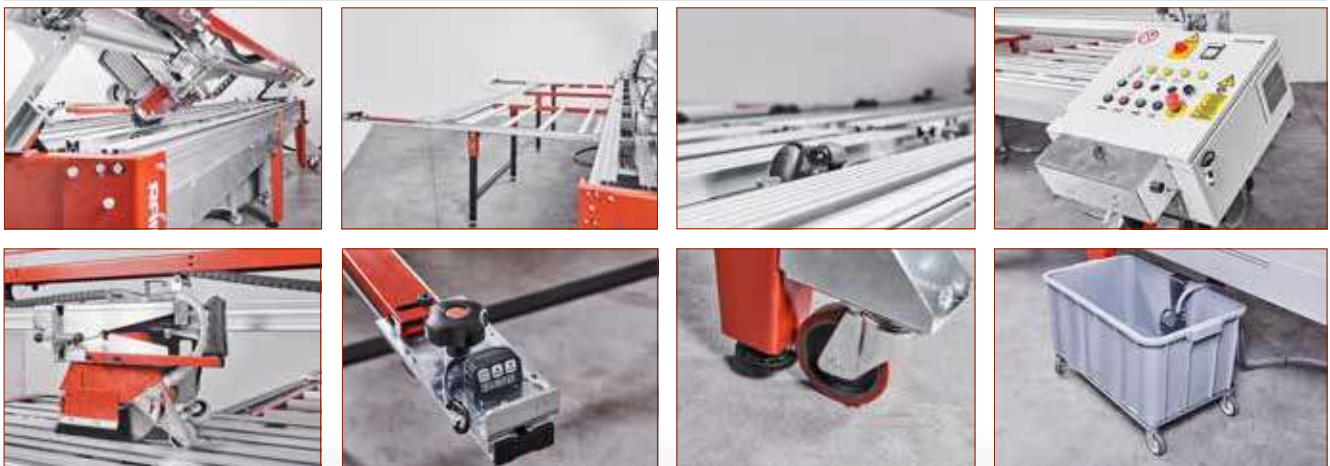

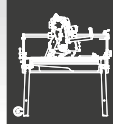

AVAILABLE BLADES

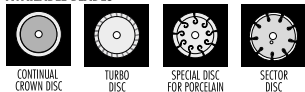

ACCESSORIES



PACKAGE

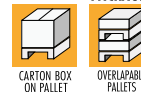

TECHNICAL CHARACTERISTICS

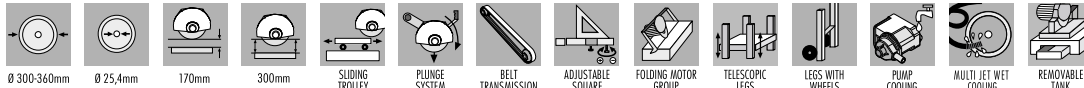

- For cutting ceramic tiles, porcelain, marble, granite, bricks, cement, etc... straight and 45° bevel (Jolly).
- Maximum length of cut: 80 cm (31 1/2").
- Maximum width of cut: 60 cm (23 5/8").
- Maximum thickness of cut single pass: 120 mm (4 3/4"); double pass: 170 mm (6 5/8").
- Aluminum framework.
- Adjust depth of cut manually.
- Tilting motor assembly 0-45°.
- Maximum blade: Ø 360 mm (14"); minimum blade: Ø 300 mm (12").

- Belt driven system optimizes motor torque and cutting capacity. Gear ratio of motor to disc 1,4 ÷ 1. Drive belt type poly V.
- Heavy duty pump and jet nozzles provide superior blade cooling.
- Removable polypropylene tank for easy cleaning. Capacity: 38 lt (10 Gal).
- Trolley is provided with anti-overturning device and locking system for safe and easy transport.
- Trolley equipped with 8 adjustable pulleys (double bearings).
- Steel made replaceable trolley guides.
- Telescopic legs provided with double safety device.
- Equipped with: segmented diamond disc Ø 360 mm (14"), wheels kit for easy transport, key kit, wrench, manual.

MODEL SPECIFICATIONS

Part No.	Barcode	Box	Lightning Bolt	M	Motor	Motor	Blade	Blade
218A	8024648019202	1	230 V 50 Hz	Single-phase	3 HP / 2,2 kW	2800	360 mm 14"	2000
218A 60HZ	8024648019240	1	230 V 60 Hz	Single-phase	3 HP / 2,2 kW	3360	360 mm 14"	2400
218A USA	8024648019226	1	110 V 60 Hz	Single-phase	3 HP / 2,2 kW	3360	360 mm 14"	2400
218A GB	8024648019219	1	115 V 50 Hz	Single-phase	3 HP / 2,2 kW	2800	360 mm 14"	2000

CUTTING SPECIFICATIONS AND MACHINE DIMENSIONS/WEIGHT

Model	Blade	Depth	Width	Length	Table	Table	Weight	Table	Weight	
SA80	360 mm 14"	120 mm 4 3/4"	65 mm 2 9/16"	80 cm 31 1/2"	60 cm 23 5/8"	50x50 cm 20"x20"	110x75xh 80 cm 43 3/8"x30"xh 31 1/2"	77 Kg 169.8 lbs	120x80xh 100 cm 47 1/4"x31 1/2"xh 39 3/8"	96 Kg 211.6 lbs





BRIDGE AND JOB SITE SAW MACHINES

SA09

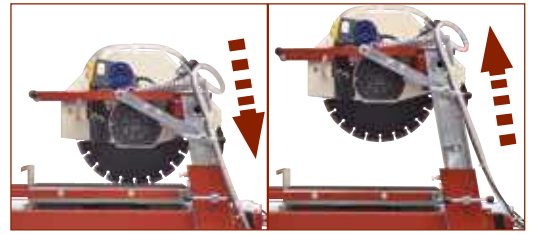

AVAILABLE BLADES

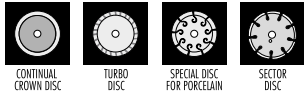

ACCESSORIES

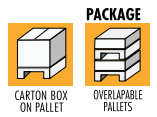
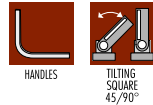

TECHNICAL CHARACTERISTICS

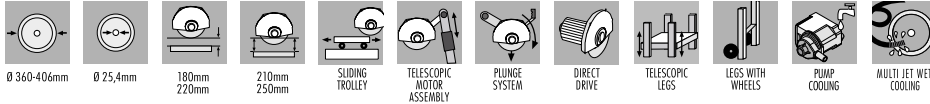

- For cutting high thickness bricks, stones, concrete, etc... Suitable also for cutting ceramic tiles, porcelain, etc... straight and 45° bevel/jolly (accessory required for 45° bevel/jolly).
- Maximum thickness of cut in single pass: 125 mm (5") with disc Ø 406 mm (16"); 105 mm (4 1/8") with disc Ø 360 mm (14").
- Maximum thickness of cut in double pass: 250 mm (10") with disc Ø 406 mm (16"); 210 mm (8 1/4") with disc Ø 360 mm (14").
- Maximum length of cut: material with thickness up to 7 cm (2 3/4"): 80 cm (31 1/2"); material with thickness 25 cm (10"): 55 cm (22").
- Adjustable depth of cut. Removable motor assembly.
- Innovative telescopic motor assembly for depth of cut maximization.
- Disc diameter: max Ø 406 mm (16"); min Ø 360 mm (14").
- Trolley is provided with anti-overturning device and locking system for safe and easy transport.
- Trolley equipped with 8 adjustable pulleys (double bearings).
- Steel made replaceable trolley guides.
- Heavy duty pump provides superior blade cooling.
- Telescopic legs provided with safety device and wheels kit.
- Equipped with: segmented diamond disc Ø 360 mm (14"), wheels kit for easy transport, key kit, wrench, manual. Handles not included.

MODEL SPECIFICATIONS

Part No.	Barcode	Box	Lightning Bolt	M	Motor	Motor	Disc	Disc
203SA09	8024648064561	1	230 V 50 Hz	Single-phase	3 HP / 2,2 kW	2800	360 mm	14"
203SA09 60HZ	8024648066510	1	230 V 60 Hz	Single-phase	3 HP / 2,2 kW	3360	360 mm	14"
203SA09 US	8024648066503	1	110 V 60 Hz	Single-phase	2 HP / 1,5 kW	3360	360 mm	14"

CUTTING SPECIFICATIONS AND MACHINE DIMENSIONS/WEIGHT

Model	Disc	SINGLE PASS	DOUBLE PASS	Height	Width	Depth	Weight	Dimensions	Weight
SA09	360 mm 14"	105 mm 4 1/8"	210 mm 8 1/4"	50 mm 2"	80 cm 31 1/2"	60 cm 23 5/8"	80 Kg 176.4 lbs	120x70xh 75 cm	99 Kg 218.3 lbs
	406 mm 16"	125 mm 5"	250 mm 10"	70 mm 2 3/4"	80 cm 31 1/2"	60 cm 23 5/8"	80 Kg 176.4 lbs	120x80xh 100 cm	99 Kg 218.3 lbs

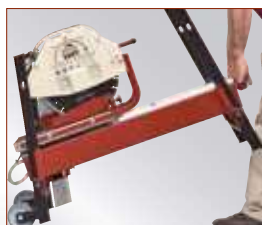

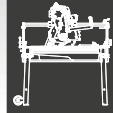

AVAILABLE BLADES



SECTOR DISC

ACCESSORIES



LASER



TILTING SQUARE

45/90°

PACKAGE



WOODEN CASE



OVERLAPABLE PALLETS

TECHNICAL CHARACTERISTICS



Ø 500-630mm



Ø 30mm



165mm
110mm



250mm



SLIDING TROLLEY



PLUNGE SYSTEM



FOLDING MOTOR GROUP



BELT TRANSMISSION



TELESCOPIC LEGS



ARRANGED FOR LIFTING EQUIPMENT



LEGS WITH WHEELS



PUMP COOLING



MULTI JET WET COOLING



REMOVABLE TANK

- For cutting high thickness bricks, stones, concrete, etc. . .
- Maximum length of cut 65 cm (25 3/8") for materials of thickness up to 16,5 cm (6 1/2").
- Maximum length of cut 40 cm (15 3/4") for materials of thickness up to 20 cm (7 7/8").
- Maximum depth of cut in single pass: 25 cm (9 7/8") with Ø 600 mm (23 5/8") disc; 20 cm (7 7/8") with Ø 500 mm (20") disc.
- Maximum depth of cut in double pass: 25 cm (9 7/8")
- Maximum length of cut with Ø 600 mm (23 3/8") blade: 70 cm (27 1/2") for materials up to 14 cm (5 1/2") thickness; 45 cm (17 1/16") for materials up to 25 cm (9 7/8") thickness.
- Maximum length of cut with Ø 500 mm (20") blade: 70 cm (27 1/2")
- Maximum blade: Ø 600 mm (23 3/8"); minimum blade: Ø 400 mm (15 3/4").
- Belt driven system optimizes motor torque and cutting capacity. Gear ratio of motor to disc 1,1 ÷ 1. Drive belt type poly V.
- Double floating blade guards provide extra safety during operation.
- Heavy duty external pump and jet nozzles provide superior blade cooling.
- Removable polypropylene tank for easy cleaning. Capacity: 56 lt (14.8 Gal).
- Trolley is provided with anti-overturning device and locking system for safe and easy transport.
- Trolley equipped with 6 adjustable pulleys (double bearings).
- Steel made replaceable trolley guides.
- Telescopic legs provided with safety device.
- Provided with hook housing for lifting equipment.
- Equipped with: key kit, wrench, user and maintenance manual.

MODEL SPECIFICATIONS

Part No.									
218AS 230SD	8024648017659	1	230 V / 50 Hz	● 2P+T / 16A	Single-phase	3,3 HP / 2,4 kW	1400	-	1260 2000
218AS 400SDN	8024648082466	1	400 V / 50 Hz	● 3P+T+N / 16A	Three-phase	4,5 HP / 3,3 kW	1400	-	1260 2000

CUTTING SPECIFICATIONS AND MACHINE DIMENSIONS/WEIGHT

Model											
SHERPA	630 mm	25 cm	13 cm	25 cm	10"	45 cm	17 1/16"	49x49 cm 19"x19"	145x75xh 110 cm 57"x30"xh 43"	137 Kg 302 lbs	170x90xh 140 cm 67"x35 1/2"xh 55"
	25"	10"	5 1/8"	14 cm	5 1/2"	70 cm	27 1/2"				
	500 mm	18 cm	11 cm	18 cm	7"	70 cm	27 1/2"				





ACCESSORIES FOR BRIDGE SAW MACHINES

MADE IN ITALY

BRIDGE AND JOB SITE SAW MACHINES

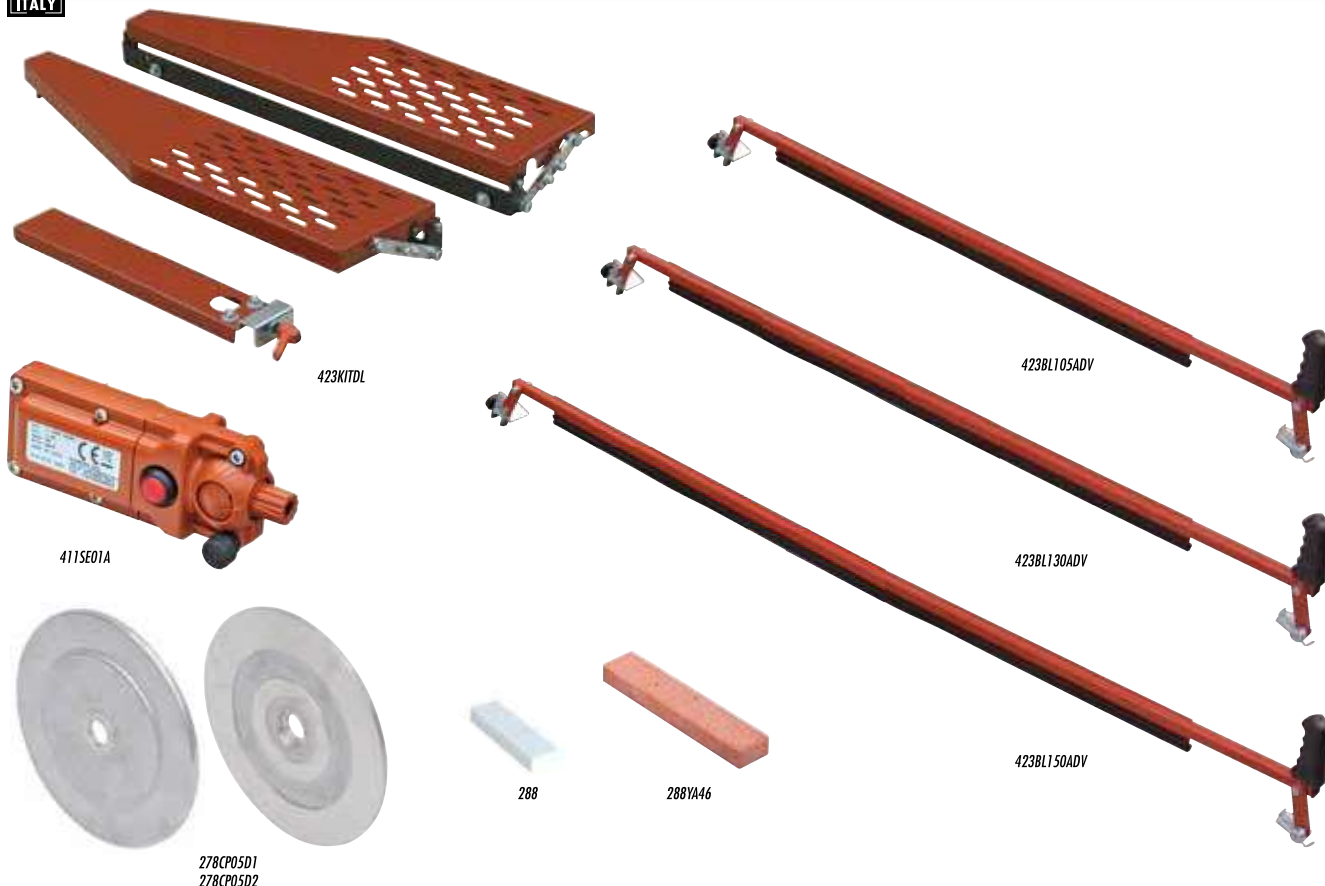

Part No.			Description				
423KITDL	8024648010476	1	Optional kit: folding extension tables and 90° left square	71x22xh 10 cm	28"x8 5/8"xh 4"	5 Kg	11 lbs
423BL105ADV	8024648056757	1	Tile holder for Pikus 105 ADV, SMS 100, Zoe 105 ADV	117x24xh 20 cm	46"x9 1/2"xh 7 7/8"	2,6 Kg	5.7 lbs
423BL130ADV	8024648066459	1	Tile holder for Pikus 130 ADV, SMS 125, Zoe 130 ADV	153x24xh 20 cm	60"x9 1/2"xh 7 7/8"	3 Kg	6.6 lbs
423BL150ADV	8024648071187	1	Tile holder for SMS150 e Zoe 150 ADV	178x24xh 20 cm	70"x9 1/2"xh 7 7/8"	3,5 Kg	7.7 lbs
411SE01A	8024648065254	1	Laser without stirrup	-	-	-	-
411SE A1	8024648070906	1	Laser with stirrup for ZOE Adv	-	-	-	-
411SE A2	8024648070913	1	Laser with stirrup for Pikus Adv	-	-	-	-
411SE A4	8024648070937	1	Laser with stirrup for SMS100,125 e 150	-	-	-	-
411SE A9	8024648005663	1	Laser with stirrup for SMS220 e SMS260	-	-	-	-
288	8024648004178	1	Dressing stone 30 x100xh 15 mm (1 3/16" x 4"xh 5/8")	-	-	-	-
288YA46	8024648079619	1	Dressing stone 45x230xh 25 mm (1 3/4"x9 1/16"xh 1")	-	-	-	-
278CP05D1	8024648079060	2	Flanges (pair) Ø 200 mm (8") per Zoe ADV	-	-	-	-
278CP05D2	8024648079077	2	Flanges (pair) Ø 200 mm (8") per SMS e Mistral	-	-	-	-

Part no.	EXPLOIT			BOLT			MISTRAL			PIKUS			PIKUS ADV			SMS			LAB		ZOE ADV			SA	SA	SHERPA			
	70	90	120	90	120	150	90	120	150	75	85	105	130	100	125	150	220	260	270	330	400	85	105	130	150		80	09	
423KITDL	-	-	-	-	-	-	-	-	-	-	•	•	•	•	•	•	•	•	•	•	•	•	•	•	•	•	-	-	
423BL105ADV	-	-	-	-	-	-	-	-	-	-	-	•	•	•	•	•	•	•	•	•	•	•	•	•	•	•	-	-	
423BL130ADV	-	-	-	-	-	-	-	-	-	-	-	•	•	•	•	•	•	•	•	•	•	•	•	•	•	•	-	-	
423BL150ADV	-	-	-	-	-	-	-	-	-	-	-	•	•	•	•	•	•	•	•	•	•	•	•	•	•	•	-	-	
411SE01A	-	-	-	-	-	-	-	-	-	-	-	-	-	-	-	-	-	-	-	-	-	-	-	-	-	-	-	-	
411SE A1	-	-	-	-	-	-	-	-	-	-	-	•	•	•	•	•	•	•	•	•	•	•	•	•	•	•	-	-	
411SE A2	-	-	-	-	-	-	-	-	-	-	-	•	•	•	•	•	•	•	•	•	•	•	•	•	•	•	-	-	
411SE A4	-	-	-	-	-	-	-	-	-	-	-	-	-	•	•	•	•	•	•	•	•	•	•	•	•	•	-	-	
411SE A9	-	-	-	-	-	-	-	-	-	-	-	-	-	-	-	•	•	•	•	•	•	•	•	•	•	•	-	-	
288	•	•	•	•	•	•	•	•	•	•	•	•	•	•	•	•	•	•	•	•	•	•	•	•	•	•	•	•	•
288YA46	•	•	•	•	•	•	•	•	•	•	•	•	•	•	•	•	•	•	•	•	•	•	•	•	•	•	•	•	•
278CP05D1	-	-	-	-	-	-	-	-	-	-	-	-	-	-	-	-	-	-	-	-	-	-	•	•	•	•	-	-	
278CP05D2	-	-	-	-	-	-	-	-	-	-	-	-	-	-	-	-	-	-	-	-	-	-	-	-	-	-	-	-	





MADE IN ITALY



BRIDGE AND JOB SITE SAW MACHINES

Part No.			Description				
374RUSD401	8024648090256	1	Self-standing 5 rollers side extension bench (length: 705mm; width: 506 mm)	80x60xh 20	31 1/2"x23 5/8"x h7 7/8"	20,7 Kg	45.6 lbs
191CL04A1	8024648080998	1	Telescopic set-square 90°/45° for Pikus Adv, SMS and Zoe Adv	80x33xh 21 cm	31 1/2"x13"xh 8 1/4"	9 Kg	19.8 lbs
192SQ03A	8024648014986	1	Sliding square 90°	42x7xh 5 cm	16 1/2"x2 3/4"xh 2"	900 gr	31.8 oz
192SQ07A	8024648053893	1	Left sliding square 45°/90°	29x22xh 7 cm	11 1/2"x8 5/8"xh 2 3/4"	900 gr	31.8 oz
191CL04A	8024648056122	1	Side square for Pikus ADV, Zoe ADV and SMS	81x45xh 13 cm	32"x17 3/4"xh 5"	4,5 Kg	10 lbs
191CL04A2	8024648088123	1	Side square for Exploit, Bolt, Mistral	100x45xh 12cm	39 3/8"x17 3/4"xh 4 3/4"	5,6 Kg	12.3 lbs
191CL05A	8024648058003	1	Side square for rolling side tables	68x66xh 10cm	27"x26"xh 4"	4,5 Kg	9.9 lbs
315CR02K	8024648089908	1	4 Wheels + handles kit for Exploit, Bolt and Mistral	33x33xh 10 cm	13"x13"xh 4"	3,3 Kg	7.3 lbs
263PE04A085	8024648019585	1	Water containment bars with nylon brushes for Pikus 85 Adv and Zoe 85 Adv	120xØ 12,5 cm	47 1/4"xØ 5"	3,6 Kg	7.9 lbs
263PE04A105	8024648019592	1	Water containment bars with nylon brushes for Pikus 105 Adv, SMS 100 and Zoe 105 Adv	120xØ 12,5 cm	47 1/4"xØ 5"	3,8 Kg	8.4 lbs
263PE04A130	8024648022233	1	Water containment bars with nylon brushes for Pikus 130 Adv, SMS 125 and Zoe 130 Adv	165xØ 12,5 cm	65"xØ 5"	4,6 Kg	10.1 lbs
263PE04A150	8024648022851	1	Water containment bars with nylon brushes for SMS 150 and Zoe 150 Adv	165xØ 12,5 cm	65"xØ 5"	4,9 Kg	10.8 lbs
263PE04A200	8024648026507	1	Water containment bars with nylon brushes for SMS 220	200xØ 12,5 cm	79"xØ 5"	6,6 Kg	14.6 lbs
263PE04A260	8050532001824	1	Water containment bars with nylon brushes for SMS 260	285xØ 12,5 cm	112"xØ 5"	7,6 Kg	16.8 lbs

Part no.	EXPLOIT			BOLT			MISTRAL			PIKUS			PIKUS ADV					SMS					LAB		ZOE ADV				SA 80	SA 09	SHERPA
	70	90	120	90	120	150	90	120	150	75	85	105	130	100	125	150	220	260	270	330	400	85	105	130	150	80	09				
374RUSD401	•	•	•	•	•	•	•	•	•	•	•	•	•	•	•	•	•	•	•	•	•	•	•	•	•	•	•	•	•		
191CL04A1	-	-	-	-	-	-	-	-	-	-	-	-	-	-	-	-	-	-	-	-	-	-	-	-	-	-	-	-	-		
192SQ03A	•	•	•	•	•	•	•	•	•	•	•	•	•	•	•	•	•	•	•	•	•	•	•	•	•	•	•	•	•		
192SQ07A	•	•	•	•	•	•	•	•	•	•	•	•	•	•	•	•	•	•	•	•	•	•	•	•	•	•	•	•	•		
191CL04A	-	-	-	-	-	-	-	-	-	-	-	-	-	-	-	-	-	-	-	-	-	-	-	-	-	-	-	-	-		
191CL04A2	-	•	•	•	•	•	•	•	•	•	•	•	•	-	-	-	-	-	-	-	-	-	-	-	-	-	-	-	-		
191CL05A	-	-	-	-	-	-	-	-	-	-	-	-	-	-	-	-	-	-	-	-	-	-	-	-	-	-	-	-	-		
315CR02K	•	•	•	•	•	•	•	•	•	•	•	•	•	-	-	-	-	-	-	-	-	-	-	-	-	-	-	-	-		
263PE04A085	-	-	-	-	-	-	-	-	-	-	-	-	-	-	-	-	-	-	-	-	-	-	-	-	-	-	-	-	-		
263PE04A105	-	-	-	-	-	-	-	-	-	-	-	-	-	-	-	-	-	-	-	-	-	-	-	-	-	-	-	-	-		
263PE04A130	-	-	-	-	-	-	-	-	-	-	-	-	-	-	-	-	-	-	-	-	-	-	-	-	-	-	-	-	-		
263PE04A150	-	-	-	-	-	-	-	-	-	-	-	-	-	-	-	-	-	-	-	-	-	-	-	-	-	-	-	-	-		
263PE04A200	-	-	-	-	-	-	-	-	-	-	-	-	-	-	-	-	-	-	-	-	-	-	-	-	-	-	-	-	-		
263PE04A260	-	-	-	-	-	-	-	-	-	-	-	-	-	-	-	-	-	-	-	-	-	-	-	-	-	-	-	-	-		





DUAL SIDE BENCHES WITH COUNTERSQUARE AND ROLLERS/CUTTING WIDTH DIGITAL DISPLAY KIT



- They can be mounted on the wet saws between 125 cm (4.1') and 400 cm (13.1') models;
- The "main benches" are the ones to be directly bolted to the machine frame. Maximum distance between the countersquare and the line of cut: 161 cm (5.3');
- The "secondary benches" or more simply "extensions" (ACCESSORIES) must be mounted on the "main benches". They allow to reach 330 cm between the countersquare and the cutting guide;
- Both the "main benches" and the "secondary benches" can be equipped with specific digital displays to measure the cutting width (standard for LAB400);
- For all details and compatibility, we recommend to first review the chart here below and, eventually, contact Raimondi staff to verify the correct settings.

Part No.	Barcode	Box	Description	Box	Weight	Volume
374BRU 130	8050532019041	1	Kit of 2 "main benches" with countersquare. Maximum distance between the countersquare and the line of cut: 161 cm (5.3'). For Pikus 130, Zoe 130, Zoe 150, SMS 125, SMS 150	130x110xh 45 cm*	4.3'x3.6'xh 1.2''	46 Kg* 101.41 lbs*
374BRU 220	8050532019058	1	Kit of 2 "main benches" with countersquare. Maximum distance between the countersquare and the line of cut: 161 cm (5.3'). For SMS 220	130x110xh 55 cm* 230x12xh 5 cm*	4.3'x3.6'xh 1.8'' 7.5'x0.4'xh 0.2''	82 Kg* 180.78 lbs*
374BRU 260	8050532020375	1	Kit of 2 "main benches" with countersquare. Maximum distance between the countersquare and the line of cut: 161 cm (5.3'). For SMS 260	130x110xh 55 cm* 270x12xh 5 cm*	4.3'x3.6'xh 1.8'' 8.9'x0.4'xh 0.2''	86 Kg* 189.60 lbs*
374VISVESTD	8050532020429	1	Digital display kit for measurement of cutting width up to 1610 mm (5.3')	190x21xh 10 cm*	6.2'x0.7'xh 0.3''	11.2 Kg* 24.69 lbs*
374BRU 1F2	8050532020351	1	Kit of 2 "secondary benches". Without countersquare. For extending width of cut up to 330 cm - 10.8' (maximum distance between line of cut and countersquare: 3300 mm - 10.8'). For Pikus 130, Zoe 130, Zoe 150, SMS 125, SMS 150	130x110xh 45 cm*	4.3'x3.6'xh 1.2''	47 Kg* 103.62 lbs*
374BRU 2F2	8050532020368	1	Kit of 2 "secondary benches". Without countersquare. For extending width of cut up to 330 cm - 10.8' (maximum distance between line of cut and countersquare: 3300 mm - 10.8'). For SMS 220, SMS 260, LAB 270, LAB 330	130x110xh 55 cm*	4.3'x3.6'xh 1.8''	70 Kg* 154.32 lbs*
374BRU 400	8050532020382	1	Kit of 2 "secondary benches". Without countersquare. For extending width of cut up to 330 cm - 10.8' (maximum distance between line of cut and countersquare: 3300 mm - 10.8'). For LAB 400	130x110xh 55 cm* 190x8xh 7 cm*	4.3'x3.6'xh 1.8'' 6.2'x0.3'xh 0.2''	75 Kg* 165.35 lbs*
374VISVEMAXI	8050532020412	1	Digital display kit for measurement of cutting width up to 3300 mm (10.8')	190x8xh 7 cm* 50x50xh 16 cm*	6.2'x0.3'xh 0.2'' 1.6'x1.6'xh 0.5''	13.2 Kg* 29.1 lbs*

* Please note: weights and volumes data are indicative and can be confirmed only when the goods are ready for shipment.

COMPATIBILITY SCHEME DUAL SIDE BENCHES WITH COUNTERSQUARE AND ROLLERS/CUTTING WIDTH DIGITAL DISPLAY KIT

WHAT DO I WANT	WET SAW MODEL											
	PIKUS		ZOE			SMS			LAB			
	130	130	150	125	150	220	260	270	330	400		
Standard configuration	without bench					without bench		bench + square min 35 max 120 cm (min 1.14' max 3.93')	2 benches + countersquare min 0 max 161 cm (min 0' max 5.3')	2 benches + countersquare min 0 max 161 cm (min 0' max 5.3')	2 benches + countersquare min 0 max 161 cm (min 0' max 5.3') + digital display kit for measurement of cutting width up to 161 cm (5.3')	
ACCESSORIES main bench/benches max width 161 cm (5.3')	art. 374BRU 130 bench + countersquare min 0 max 161 cm (min 0' max 5.3')					art. 374BRU 220 2 benches + countersquare min 0 max 161 cm (min 0' max 5.3')		art. 374BRU 260 2 benches + countersquare min 0 max 161 cm (min 0' max 5.3')		2 benches included in the machine	2 benches included in the machine	2 benches included in the machine
Digital display kit for measurement of cutting width up to 161 cm (5.3') (usable only in combination with "main" bench/benches)	art. 374VISVEST 2 digital displays kit for measurement of cutting width with profiles and magnetic stripes min 0 max 161 cm (min 0' max 5.3')										Digital display kit for measurement of cutting width included in the machine	
ACCESSORIES secondary bench/benches (exten- sions) max width 330 cm (10.8') (usable only in combination with "main" bench/benches)	art. 374BRU 1F2 bench WITHOUT countersquare min 0 max 330 cm (min 0' max 10.8')					art. 374BRU 2F2 2 benches WITHOUT countersquare min 0 max 330 cm (min 0' max 10.8')					art. 374BRU 400 2 benches WITHOUT countersquare min 0 max 330 cm (min 0' max 10.8') + predisposition for the digital display to reach 330cm wide cuts.	
Digital display kit for measurement of cutting width up to 330 cm (10.8') (usable only in combination with "secondary" bench/benches - extensions)	art. 374VISVEMAXI 2 digital displays kit for measurement of cutting width with profiles and magnetic stripes min 0 max 330 cm (min 0' max 10.8')										Digital display kit for measurement of cutting width included in the machine	

* For all details and compatibility, we recommend to first review the chart here below and, eventually, contact Raimondi staff to verify the correct settings.



MADE IN ITALY

BRIDGE AND JOB SITE SAW MACHINES



Part No.			Description
419AVBO=120	8024648090331	1	Wheel kit feed for Bolt 120
419AVBO=150	8024648090348	1	Wheel kit feed for Bolt 150
419AVMS=120	8024648090355	1	Wheel kit feed for Mistral 120/SMS 125
419AVMS=150	8024648090362	1	Wheel kit feed for Mistral 150
419AVMS=155	8024648022714	1	Wheel kit feed for SMS 150
419AVPK 085	8024648091543	1	Wheel kit feed for Pikus 85 Adv
419AVPK 105	8024648091550	1	Wheel kit feed for Pikus 105 Adv
419AVPK 130	8024648092755	1	Wheel kit feed for Pikus 130 Adv
419AVZO 085	8024648093233	1	Wheel kit feed for Zoe 85 Adv
419AVZO 105	8024648093240	1	Wheel kit feed for Zoe 105 Adv
419AVZO 130	8024648093257	1	Wheel kit feed for Zoe 130 Adv
419AVZO 150	8024648093264	1	Wheel kit feed for Zoe 150 Adv

Part no.	EXPLOIT			BOLT		MISTRAL			PIKUS		PIKUS ADV		SMS				LAB			ZOE ADV			SA 80	SA 09	SHERPA		
	70	90	120	90	120	150	90	120	150	75	85	105	130	100	125	150	220	260	270	330	400	85	105	130		150	
419AVBO=120	-	-	-	-	•	-	-	-	-	-	-	-	-	-	-	-	-	-	-	-	-	-	-	-	-	-	-
419AVBO=150	-	-	-	-	-	•	-	-	-	-	-	-	-	-	-	-	-	-	-	-	-	-	-	-	-	-	-
419AVMS=120	-	-	-	-	-	-	•	-	-	-	-	-	-	-	•	-	-	-	-	-	-	-	-	-	-	-	-
419AVMS=150	-	-	-	-	-	-	-	•	-	-	-	-	-	-	-	•	-	-	-	-	-	-	-	-	-	-	-
419AVMS=155	-	-	-	-	-	-	-	-	-	-	-	-	-	-	-	•	-	-	-	-	-	-	-	-	-	-	-
419AVPK 085	-	-	-	-	-	-	-	-	-	-	•	-	-	-	-	-	-	-	-	-	-	-	-	-	-	-	-
419AVPK 105	-	-	-	-	-	-	-	-	-	-	-	•	-	-	-	-	-	-	-	-	-	-	-	-	-	-	-
419AVPK 130	-	-	-	-	-	-	-	-	-	-	-	-	•	-	-	-	-	-	-	-	-	-	-	-	-	-	-
419AVZO 085	-	-	-	-	-	-	-	-	-	-	-	-	-	-	-	-	-	-	-	-	-	•	-	-	-	-	-
419AVZO 105	-	-	-	-	-	-	-	-	-	-	-	-	-	-	-	-	-	-	-	-	-	-	•	-	-	-	-
419AVZO 130	-	-	-	-	-	-	-	-	-	-	-	-	-	-	-	-	-	-	-	-	-	-	-	•	-	-	-
419AVZO 150	-	-	-	-	-	-	-	-	-	-	-	-	-	-	-	-	-	-	-	-	-	-	-	-	•	-	-



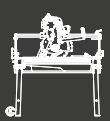

BRIDGE AND JOB SITE SAW MACHINES

ACCESSORIES FOR TROLLEY MACHINES

**MADE
IN
ITALY**



192SQ24A



218DJ

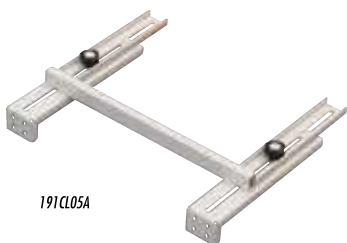

191CLO5A



288



288YA46



154SE17CP



411SE01A

Part No.			Description				
192SQ24A	8024648005656	1	Adjustable square 0/45°/90° for SA80, SA09, SHERPA	40x17xh 8 cm	16"×6 3/4"×h 3 1/8"	1,5 Kg	3.3 lbs
218DJ	8024648009777	1	Jolly device for SA09	71x23xh 11cm	28"×9"×h 4"	4,4 Kg	9.7 lbs
154SE17CP	8024648066480	1	Handles for SA09	40x28xh 18 cm	15 3/4"×11"×h 7"	6 Kg	13 lbs
191CLO5A	8024648058003	1	Side square for SA80	68x66xh 10cm	27"×26"×h 4"	4,5 Kg	9.9 lbs
411SE01A	8024648065254	1	Laser without stirrup	–	–	–	–
411SE A4	8024648070937	1	Laser with stirrup for SMS and SA80	–	–	–	–
411SE A3	8024648070920	1	Laser with stirrup for Sherpa	–	–	–	–
288	8024648004178	1	Dressing stone 30 x100xh 15 mm (1 3/16" x 4" xh 5/8")	–	–	–	–
288YA46	8024648079619	1	Dressing stone 45x230xh 25 mm (1 3/4" x9 1/16" xh 1")	–	–	–	–

Part no.	EXPLOIT			BOLT			MISTRAL			PIKUS			PIKUS ADV			SMS					LAB		ZOE ADV				SA	SA	SHERPA			
	70	90	120	90	120	150	90	120	150	75	85	105	130	100	125	150	220	260	270	330	400	85	105	130	150	80	09					
192SQ24A	–	–	–	–	–	–	–	–	–	–	–	–	–	–	–	–	–	–	–	–	–	–	–	–	–	–	–	–	–	•	•	•
218DJ	–	–	–	–	–	–	–	–	–	–	–	–	–	–	–	–	–	–	–	–	–	–	–	–	–	–	–	–	–	•	•	–
154SE17CP	–	–	–	–	–	–	–	–	–	–	–	–	–	–	–	–	–	–	–	–	–	–	–	–	–	–	–	–	•	•	•	
191CLO5A	–	–	–	–	–	–	–	–	–	–	•	•	•	•	•	•	•	•	–	–	–	–	•	•	•	•	•	–	–	–	–	
411SE01A	–	–	–	–	–	–	–	–	–	–	–	–	–	–	–	–	–	–	–	–	–	–	–	–	–	–	–	–	–	–	–	
411SE A4	–	–	–	–	–	–	–	–	–	–	–	–	–	•	•	•	•	–	–	–	–	–	–	–	–	–	–	–	–	–	–	
411SE A3	–	–	–	–	–	–	–	–	–	–	–	–	–	–	–	–	–	–	–	–	–	–	–	–	–	–	–	–	–	–	•	
288	•	•	•	•	•	•	•	•	•	•	•	•	•	•	•	•	•	•	•	•	•	•	•	•	•	•	•	•	•	•	•	•
288YA46	•	•	•	•	•	•	•	•	•	•	•	•	•	•	•	•	•	•	•	•	•	•	•	•	•	•	•	•	•	•	•	•

